

NOTE: ALL MATERIAL COMPLIANT ROHS STANDARD

REVISION INFORMATION			
Rev.	Rev. Date	Modified By	Brief Description
	2024.06.26	FYQ	CHANGE LOGO

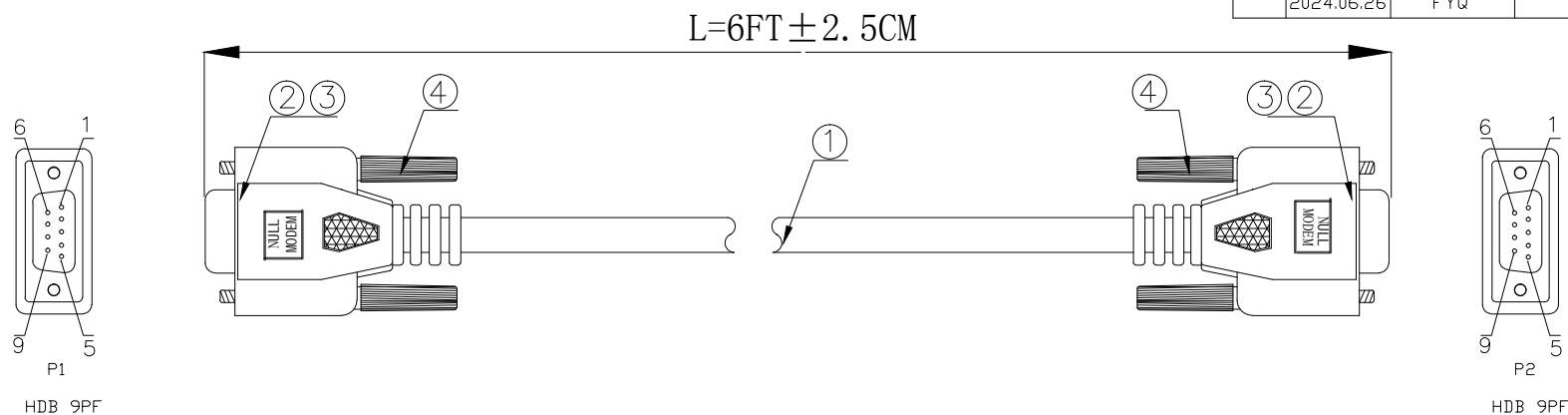

Technical Requirements

1. Electrical Characteristics:

1.1. cable must pass electrical testing, no short circuit, open circuit, indirect sexual contact, insufficient insulation, dislocation, and other electrical contact resistance of adverse circumstances

1.2 Electrical Test Conditions

Conductor Resistance: 10 Ω

2. Appearance requirements:

2.1 No shot short, shrink, flow liner

2.2 Wire surface printing clear, smooth appearance, can not have scratches and obvious color

2.3 Terminals can not have oxidation or electrodeposited coating fall off

3. Packing: Circle around a single package.

Wire point

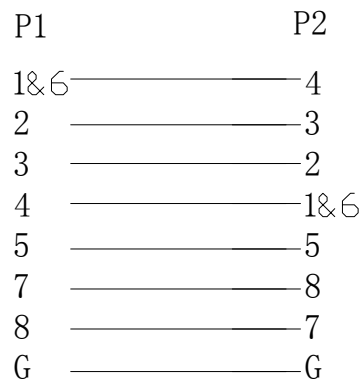

Wire Details

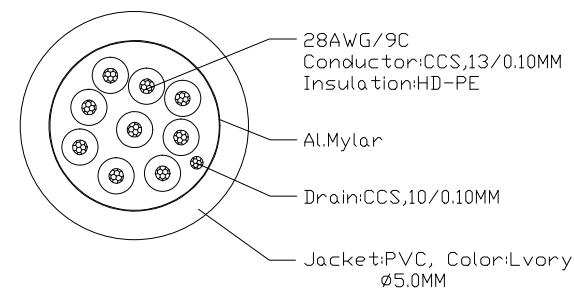

1). Material List :

NO.	PART NAME	SPECIFICATION DESCRIPTION	QTY	UNIT
④	SCREW	2.3*45MM Ivory color screw stem	4	PCS
③	Outer Moolding	45P PVC Ivory color plugs	NA	KG
②	Connector	DB 9PF two rows of blue iron shell plating nickel	2	PCS
①	Wire	28# (13/0.10CCS)*9C+D (10/0.10CCS)+AL+PVC, Lvory, OD: 5.0MM	6	FT



DRAWN BY	DATE: 2024.06.26	DESCRIPTION: 6Ft DB9-F/F Null Modem Cable	
CHECKED BY	SHEET 1 of 1	ITEM NO. 180503	
APPROVED BY	SCALE 1:1	REV. 00	UNIT: mm

NOTE: ALL MATERIAL COMPLIANT ROHS STANDARD

REVISION INFORMATION			
Rev.	Rev. Date	Modified By	Brief Description

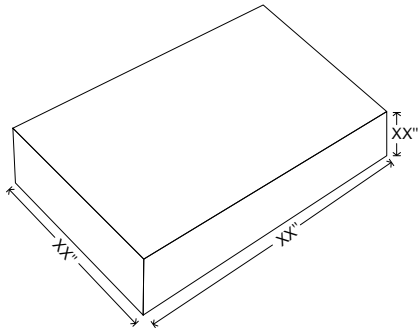

Unit package

Size: 5.9"(L)*8.27"(W)*0.16"(H)

Weight: 0.26 LBS

P/O:*****
P/N:180503
Q'TY:150PCS
C/NO.:D***

MADE IN CHINA

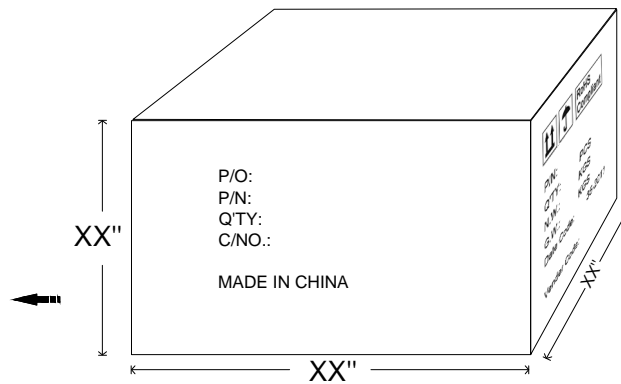

Carton Size: 21.26"(L)*14.57"(W)*8.67"(H)

Carton Quantity: 150 pcs

Carton Weight: 41.45 LBS

		RoHS Compliant
P/N: 180503		
Q'TY: 150 PCS		
N.W.: 18 KGS		
G.W.: 18.8 KGS		
Date Code: 35-2011		
Vender Code:		

DRAWN BY	DATE: 2024.06.26	DESCRIPTION: 6Ft DB9-F/F Null Modem Cable	
CHECKED BY	SHEET 1 of 1	ITEM NO. 180503	
APPROVED BY	SCALE 1:1	REV. 00	UNIT: mm