

NOTE: ALL MATERIAL COMPLIANT ROHS STANDARD

REVISION INFORMATION			
Rev.	Rev. Date	Modified By	Brief Description
	2024.06.26	FYQ	CHANGE LOGO

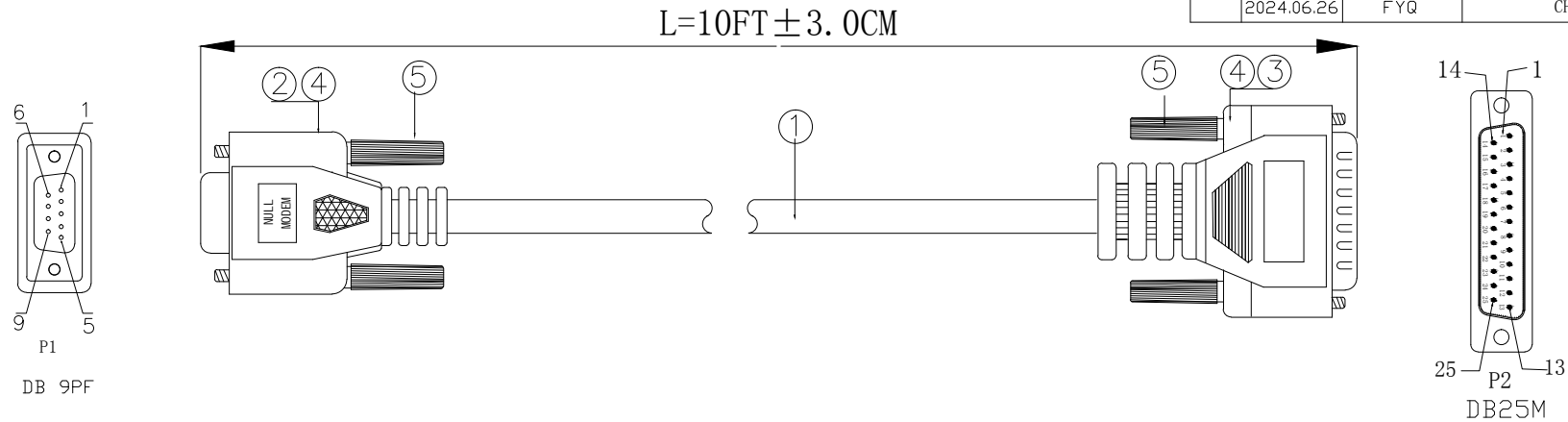

### Wire point

P1	P2
1	4&5
2	2
3	3
4	6
5	7
6	20
7&8	8
9	22
G	G

### Wire Details

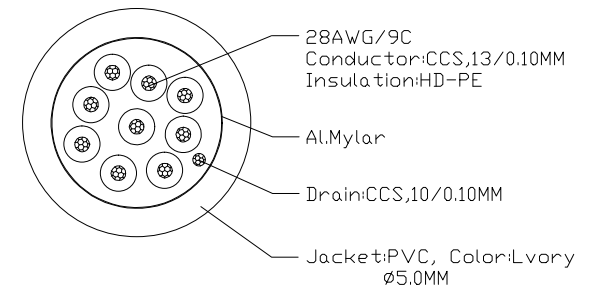

### Technical Requirements

#### 1.Electrical Characteristics:

1.1.cable must pass electrical testing, no short circuit, open circuit, indirect sexual contact, insufficient insulation, dislocation, and other electrical contact resistance of adverse circumstances

#### 1.2 Electrical Test Conditions

Conductor Resistance:10 Ω

#### 2.Appearance requirements:

2.1 No shot short.shrink. flow liner

2.2 Wire surface printing clear, smooth appearance, can not have scratches and obvious color

2.3 Terminals can not have oxidation or electrodeposited coating fall off

3.Packing: Circle around a single package.

### 1).Material List :

NO.	PART NAME	SPECIFICATION DESCRIPTION	QTY	UNIT
⑤	SCREW	2. 3*45MM Ivory color screw stem	4	PCS
④	Outer Moaldding	45P PVC Ivory color plugs	NA	KG
③	Connector	DB 25PM two rows of blue iron shell plating nickel	1	PCS
②	Connector	DB 9PF two rows of blue iron shell plating nickel	1	PCS
①	Wire	28# (13/0. 10CCS)*9C+D (10/0. 10CCS)+AL+PVC, Lvory, OD: 5. 0MM	10	FT



DRAWN BY	DATE: 2024.06.26	DESCRIPTION: 10Ft DB9-F/DB25-M Null Modem Cable	
CHECKED BY	SHEET 1 of 1	ITEM NO. 180502	
APPROVED BY	SCALE 1:1	REV. 00	UNIT: mm

NOTE: ALL MATERIAL COMPLIANT ROHS STANDARD

REVISION INFORMATION

Rev.	Rev. Date	Modified By	Brief Description

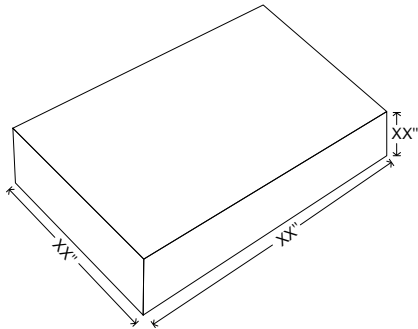

Unit package

Size: 7.08"(L)\*9.84"(W)\*0.15"(H)

Weight: 0.40 LBS

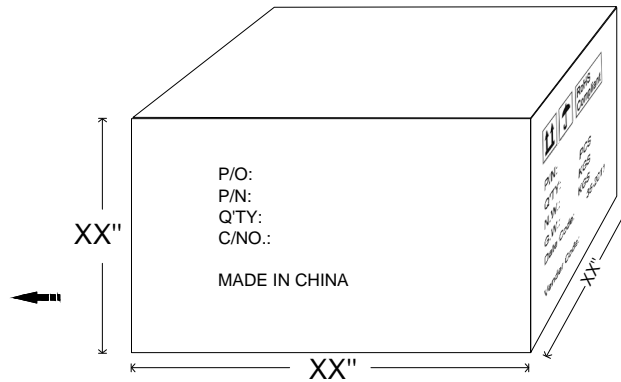

Carton Size: 21.26"(L)\*14.57"(W)\*8.67"

(H)Carton Quantity: 100 pcs

Carton Weight: 41.45 LBS

		RoHS Compliant
P/N: 180502		
Q'TY: 100 PCS		
N.W.: 18.0 KGS		
G.W.: 18.8 KGS		
Date Code: 35-2011		
Vender Code:		

DRAWN BY	DATE: 2024.06.26	DESCRIPTION: 10Ft DB9-F/DB25-M Null Modem Cable	
CHECKED BY	SHEET 1 of 1	ITEM NO. 180502	
APPROVED BY	SCALE 1:1	REV. 00	UNIT: mm