

NOTE: ALL MATERIAL COMPLIANT ROHS STANDARD

REVISION INFORMATION			
Rev.	Rev. Date	Modified By	Brief Description
	2024.06.26	FYQ	CHANGE LOGO

100FT ± 30CM

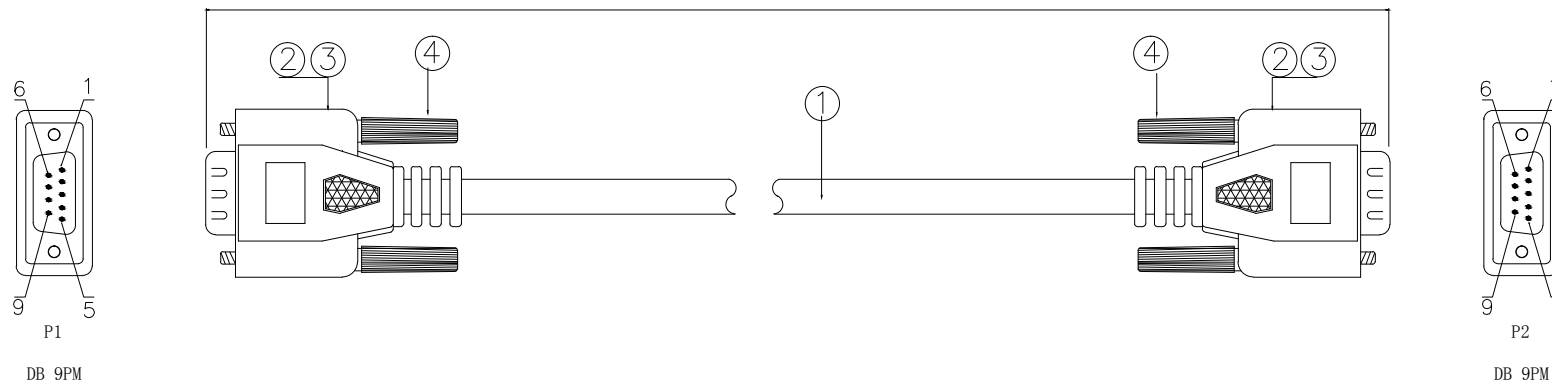

Wire point

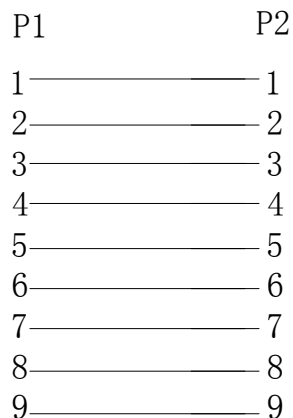

shell — D — shell

Technical Requirements

1.Electrical Characteristics:

1.1.cable must pass electrical testing, no short circuit, open circuit, indirect sexual contact, insufficient insulation, dislocation, and other electrical contact resistance of adverse circumstances

1.2 Electrical Test Conditions

Conductor Resistance:30 Ω

2.Appearance requirements:

2.1 No shot short,shrink, flow liner

2.2 Wire surface printing clear, smooth appearance, can not have scratches and obvious color

2.3 Terminals can not have oxidation or electrodeposited coating fall off

3.Packing: Circle around a single package.

Wire Details

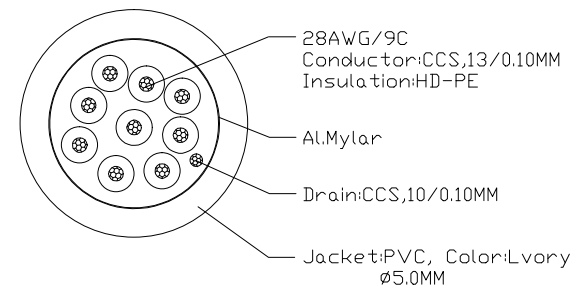

1).Material List :

NO.	PART NAME	SPECIFICATION DESCRIPTION	QTY	UNIT
④	SCREW	2.3*45MM IVORY color screw stem	4	PCS
③	Outer Moalading	45P PVC IVORY color plugs	NA	KG
②	Connector	DB 9PM two rows of blue iron shell plating nickel	2	PCS
①	Wire	28# (13/0. 10CCS)*9C+D(10/0. 10CCS)+AL+PVC, Lvory, OD:5. 0MM	100	ft

DRAWN BY	DATE: 2024.06.26	DESCRIPTION: 100Ft DB9 Male to Male Serial Cable
CHECKED BY	SHEET 1 of 1	ITEM NO. 180235
APPROVED BY	SCALE 1:1	REV. 00 UNIT: mm

NOTE: ALL MATERIAL COMPLIANT ROHS STANDARD

REVISION INFORMATION

Rev.	Rev. Date	Modified By	Brief Description

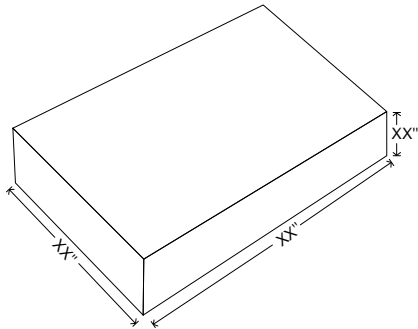

Unit package

Size: 10.43"(L)\*13.19"(W)\*0.31"(H)

Weight: 2.35 LBS

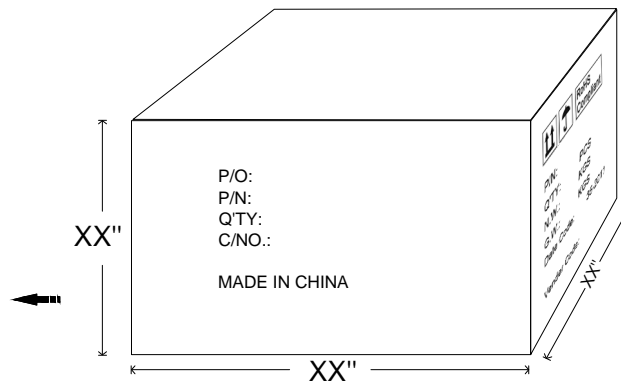
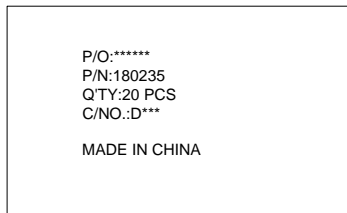

		RoHS Compliant
P/N: 180235		
Q'TY: 20 PCS		
N.W.: 20.5 KGS		
G.W.: 21.3 KGS		
Date Code: 35-2011		
Vender Code:		

Carton Size: 21.26"(L)\*14.57"(W)\*8.67"(H)

Carton Quantity: 20 pcs

Carton Weight: 46.96 LBS



DRAWN BY	DATE: 2024.06.26	DESCRIPTION: 100Ft DB9 Male to Male Serial Cable
CHECKED BY	SHEET 1 of 1	ITEM NO. 180235
APPROVED BY	SCALE 1:1	REV. 00 UNIT: mm