

NOTE: ALL MATERIAL COMPLIANT ROHS STANDARD

REVISION INFORMATION			
Rev.	Rev. Date	Modified By	Brief Description
	2024.06.26	FYQ	CHANGE LOGO

50FT ± 15CM

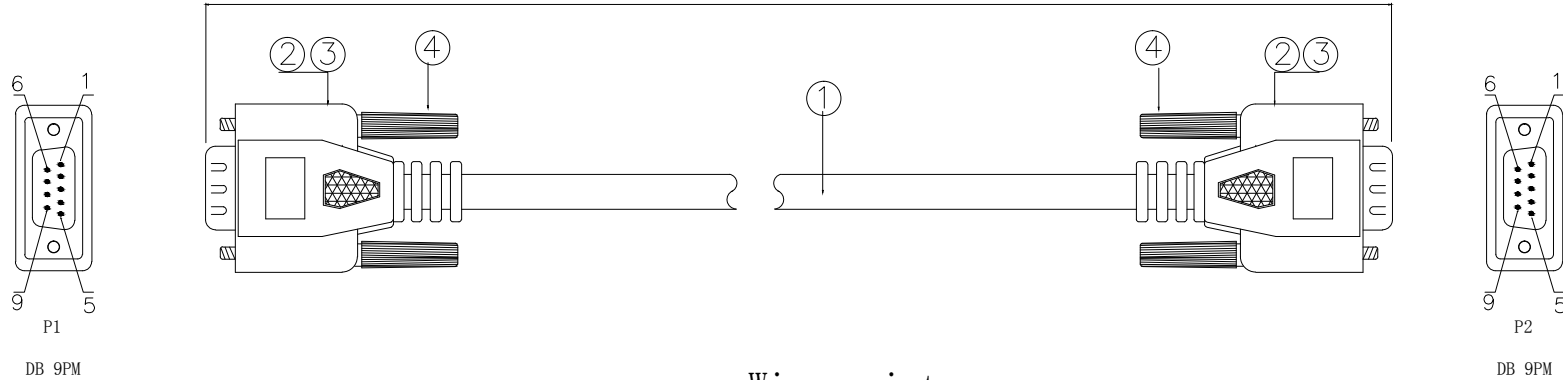

Wire point

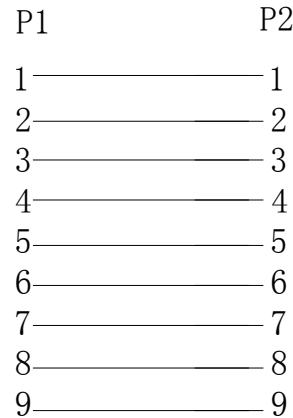

shell — D — shell

Technical Requirements

1. Electrical Characteristics:

1.1. cable must pass electrical testing, no short circuit, open circuit, indirect sexual contact, insufficient insulation, dislocation, and other electrical contact resistance of adverse circumstances

1.2 Electrical Test Conditions

Conductor Resistance: 30 Ω

2. Appearance requirements:

2.1 No shot short, shrink, flow liner

2.2 Wire surface printing clear, smooth appearance, can not have scratches and obvious color

2.3 Terminals can not have oxidation or electrodeposited coating fall off

3. Packing: Circle around a single package.

Wire Details

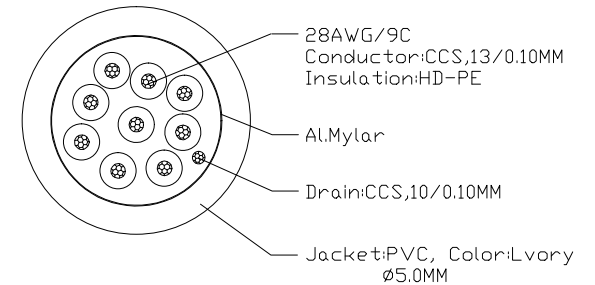

1). Material List :

NO.	PART NAME	SPECIFICATION DESCRIPTION	QTY	UNIT
④	SCREW	2. 3*45MM IVORY color screw stem	4	PCS
③	Outer Moalading	45P PVC IVORY color plugs	NA	KG
②	Connector	DB 9PM two rows of blue iron shell plating nickel	2	PCS
①	Wire	28# (13/0. 10CCS) *9C+D (10/0. 10CCS) +AL+PVC, Lvory, OD: 5. 0MM	50	ft



DRAWN BY	DATE: 2024.06.26	DESCRIPTION: 50Ft DB9 Male to Male Serial Cable
CHECKED BY	SHEET 1 of 1	ITEM NO. 180234
APPROVED BY	SCALE 1:1	REV. 00 UNIT: mm

NOTE: ALL MATERIAL COMPLIANT ROHS STANDARD

REVISION INFORMATION			
Rev.	Rev. Date	Modified By	Brief Description

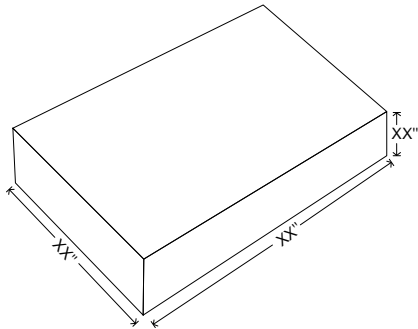

Unit package

Size: 10.43"(L)\*13.19"(W)\*0.31"(H)

Weight: 1.50 LBS

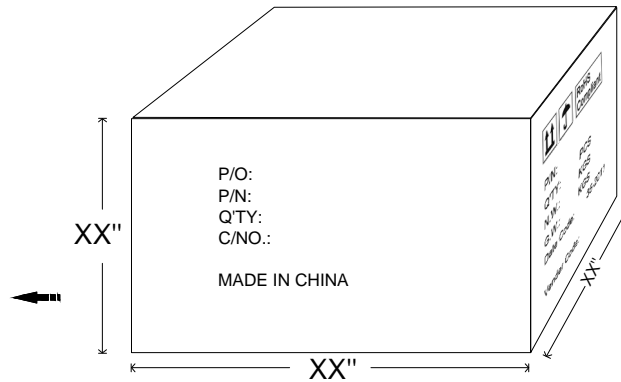

Carton Size: 21.26"(L)\*14.57"(W)\*8.67"(H)

Carton Quantity: 30 pcs

Carton Weight: 46.96 LBS

DRAWN BY	DATE: 2024.06.26	DESCRIPTION: 50Ft DB9 Male to Male Serial Cable	
CHECKED BY	SHEET 1 of 1	ITEM NO. 180234	
APPROVED BY	SCALE 1:1	REV. 00	UNIT: mm