

NOTE: ALL MATERIAL COMPLIANT ROHS STANDARD

REVISION INFORMATION			
Rev.	Rev. Date	Modified By	Brief Description
	2024.06.26	FYQ	CHANGE LOGO

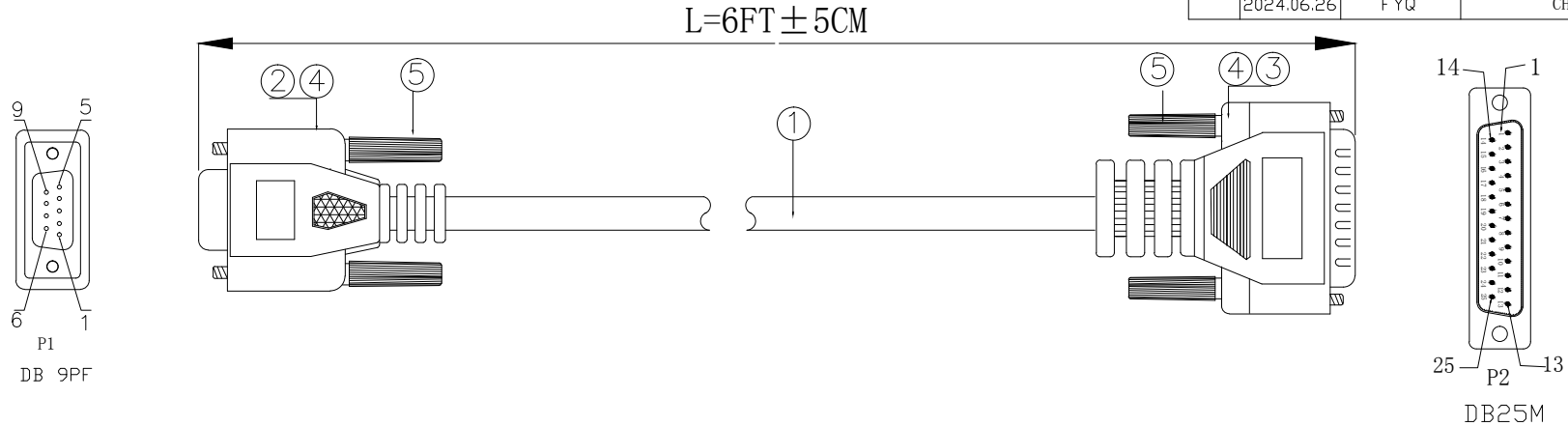

Line a table

DB 9PF	DB25M
1	8
2	3
3	2
4	20
5	7
6	6
7	4
8	5
9	22
G	G

Technical Requirements

1.Electrical Characteristics:

Electrical testing should be finished 11, cannot have short circuit breakers, intermittent contact, insulation, dislocation, contact resistance and electrical adverse circumstances.

1.2 Electrical Test Conditions

Conduction impedance:10Ω
Insulation resistance:10MΩ/300V

2.Appearance requirements:

There can be no external formwork 2.1, full mould flow lines and shrink wait for a phenomenon.

2.2 Wire surface printing clean, smooth, do not have clear off color and scratches.

Do not have 230 terminals oxidation and electric plating falls off phenomenon.

3.Packing: Blank PE bag+TAB, a single round packaging.

Wire Details

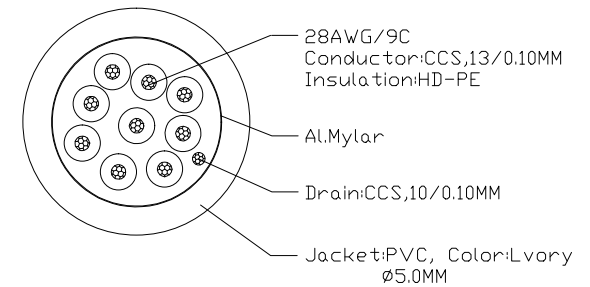

1). Material List :

NO.	PART NAME	SPECIFICATION DESCRIPTION	QTY	UNIT
⑤	SCREW	2.3*45MM Ivory color screw stem	4	PCS
④	Outer Moalging	45P PVC Ivory color plugs	NA	KG
③	Connector	DB 25PM two rows of blue iron shell plating nickel	1	PCS
②	Connector	DB 9PF two rows of blue iron shell plating nickel	1	PCS
①	Wire	28# (13/0. 10CCS) *9C+D(10/0. 10CCS) +AL+PVC, Lvory, OD:5. 0MM	1	FT



DRAWN BY	DATE: 2024.06.26	DESCRIPTION: 6Ft DB9-F/DB25-M Serial Cable
CHECKED BY	SHEET 1 of 1	ITEM NO. 180221
APPROVED BY	SCALE 1:1	REV. 00 UNIT: mm

NOTE: ALL MATERIAL COMPLIANT ROHS STANDARD

REVISION INFORMATION

Rev.	Rev. Date	Modified By	Brief Description

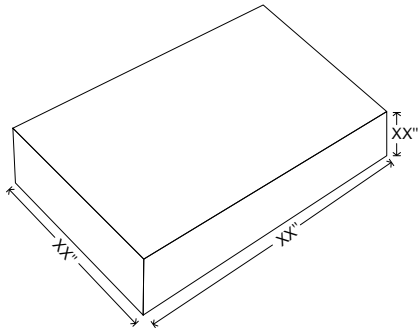

Unit package

Size: 7.08"(L)*9.84"(W)*0.15"(H)

Weight: 0.31LBS

P/O:*****
P/N:180221
Q'TY:100 PCS
C/NO.:D***

MADE IN CHINA

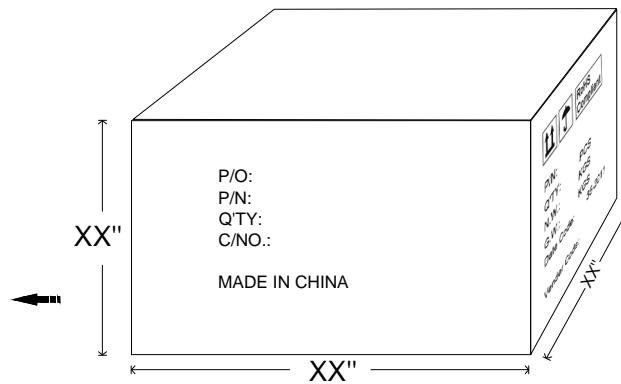

Carton Size: 21.26"(L)*14.57"(W)*8.67"(H)

Carton Quantity: 100 pcs

Carton Weight: 32.4 LBS

DRAWN BY	DATE: 2024.06.26	DESCRIPTION: 6Ft DB9-F/DB25-M Serial Cable
CHECKED BY	SHEET 1 of 1	ITEM NO. 180221
APPROVED BY	SCALE 1:1	REV. 00 UNIT: mm