

NOTE: ALL MATERIAL COMPLIANT ROHS STANDARD

REVISION INFORMATION			
Rev.	Rev. Date	Modified By	Brief Description
	2024.06.26	FYQ	CHANGE LOGO

15FT ± 5.0CM

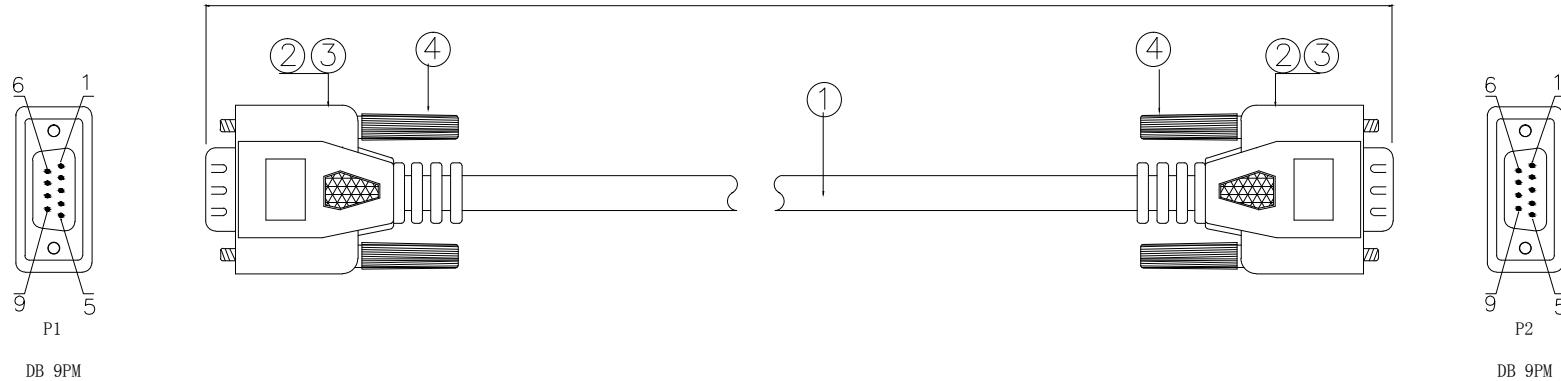

Wire point

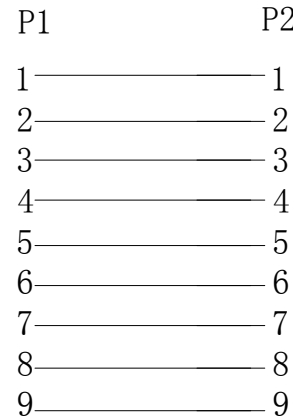

shell ——— D ——— shell

Wire Details

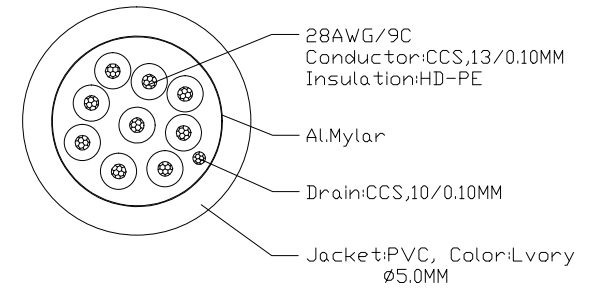

Technical Requirements

1.Electrical Characteristics:

1.1.cable must pass electrical testing, no short circuit, open circuit, indirect sexual contact, insufficient insulation, dislocation, and other electrical contact resistance of adverse circumstances

1.2 Electrical Test Conditions

Conductor Resistance:20 Ω

2.Appearance requirements:

2.1 No shot short.shrink. flow liner

2.2 Wire surface printing clear, smooth appearance, can not have scratches and obvious color

2.3 Terminals can not have oxidation or electrodeposited coating fall off

3.Packing: Circle around a single package.

1).Material List :

NO.	PART NAME	SPECIFICATION DESCRIPTION	QTY	UNIT
④	SCREW	2. 3*45MM IVORY color screw stem	4	PCS
③	Outer Moaldding	45P PVC IVORY color plugs	NA	KG
②	Connector	DB 9PM two rows of blue iron shell plating nickel	2	PCS
①	Wire	28#(13/0. 10CCS)*9C+D(10/0. 10CCS)+AL+PVC, Lvory, OD:5. 0MM	15	ft



DRAWN BY	DATE: 2024.06.26	DESCRIPTION: 15Ft DB9 Male to Male Serial Cable
CHECKED BY	SHEET 1 of 1	ITEM NO. 180213
APPROVED BY	SCALE 1:1	REV. 00 UNIT: mm

NOTE: ALL MATERIAL COMPLIANT ROHS STANDARD

REVISION INFORMATION			
Rev.	Rev. Date	Modified By	Brief Description

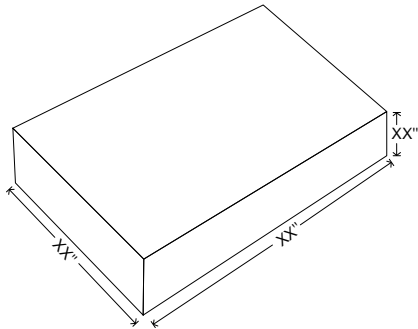

Unit package



Size: 7.08"(L)*9.84"(W)*0.15"(H)

Weight: 0.46 LBS

P/O:*****
P/N: 180213
Q'TY:100 PCS
C/NO.:D***

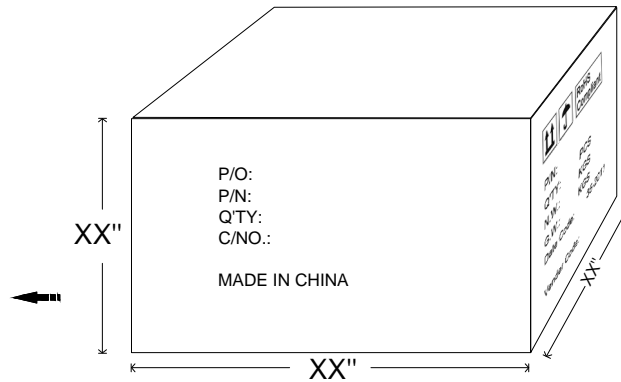
MADE IN CHINA



  RoHS Compliant

P/N: 180213
Q'TY: 100 PCS
N.W.: 20.7 KGS
G.W.: 21.5 KGS
Date Code: 35-2011

Vender Code:

Carton Size: 21.26"(L)*14.57"(W)*8.67"(H)

Carton Quantity: 100 pcs

Carton Weight: 47.4 LBS



DRAWN BY	DATE: 2024.06.26	DESCRIPTION: 15Ft DB9 Male to Male Serial Cable
CHECKED BY	SHEET 1 of 1	ITEM NO. 180213
APPROVED BY	SCALE 1:1	REV. 00 UNIT: mm 