

NOTE: ALL MATERIAL COMPLIANT ROHS STANDARD

REVISION INFORMATION

Rev.	Rev. Date	Modified By	Brief Description

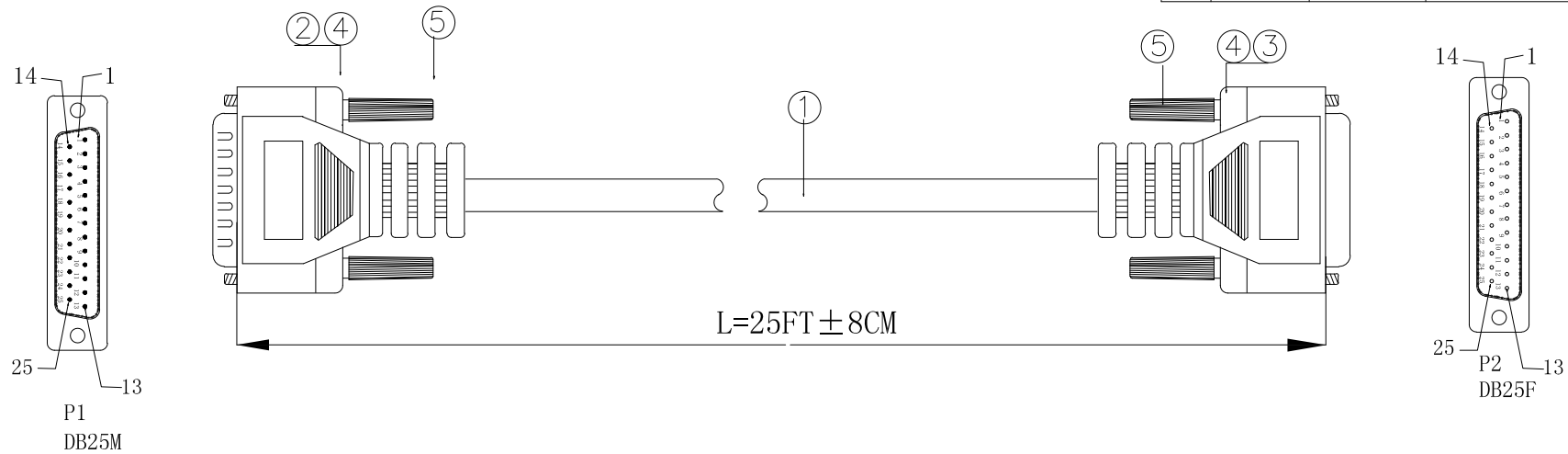

Technical requirements

1 electrical characteristics:  
Electrical testing should be finished 1.1, cannot have short circuit breakers, intermittent contact, insulation, dislocation, contact resistance and electrical adverse circumstances.

1.2 electrical test conditions

.. conduction impedance: 10 Ω

Insulation resistance: 15Ω / 300V

2 appearance requirements:

There can be no external formwork 2.1, full mould flow lines and shrink wait for a phenomenon.

2.2 wire surface clean, smooth, do not have clear off color and scratches.

Do not have 230 terminals oxidation and electric plating falls off phenomenon.

Packing:

3. Blank PE bag + TAB, a single round packaging.

PIN ASSIGNMENT:

DB 25P/M	DB 25P/F	DB 25P/M	DB 25P/F
1 — BLACK	1	16 — WHITE+ORANGE	16
2 — BROWN	2	17 — YELLOW+BLACK	17
3 — RED	3	18 — WHITE+GREEN	18
4 — ORANGE	4	19 — WHITE+BLUE	19
5 — YELLOW	5	20 — WHITE+PURPLE	20
6 — GREEN	6	21 — GRAY+BLACK	21
7 — BLUE	7	22 — PINK+BLACK	22
8 — PURPLE	8	23 — RED+BLACK	23
9 — GRAY	9	24 — ORANGE+BLACK	24
10 — WHITE	10	25 — GREEN+BLACK	25
11 — PINK	11	Shell — Shell	Shell
12 — PALE GREEN	12		
13 — WHITE+BLACK	13		
14 — WHITE+BROWN	14		
15 — WHITE+RED	15		

Wire Details

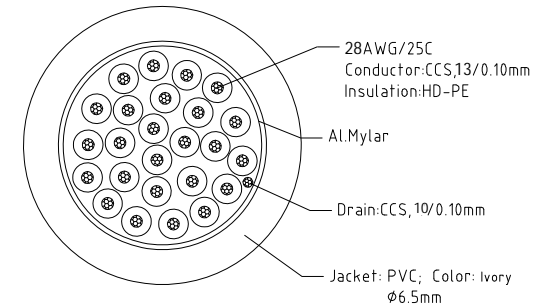

1). Material List :

NO.	PART NAME	SPECIFICATION DESCRIPTION	QTY	UNIT
⑤	SCREW	2.3*47MM color screw stem	4	PCS
④	Outer Moolding	45P PVC Ivory color plugs	NA	KG
③	Connector	DB 25PF two rows of blue iron shell plating nickel	1	PCS
②	Connector	DB 25PM two rows of blue iron shell plating nickel	1	PCS
①	Wire	(13/0.10CCS)×25C+D+A+PVC,Ivory,OD6.5mm	25	ft



DRAWN BY	DATE: 2025. 2. 6	DESCRIPTION: 25FT DB25M/Fserial Cable 25C Straight
CHECKED BY	SHEET 1 of 1	ITEM NO. 180209
APPROVED BY	SCALE 1:1	REV. 00 UNIT: mm

NOTE: CARTON MATERIAL MUST BE A=A

REVISION INFORMATION			
Rev.	Rev. Date	Modified By	Brief Description

front side

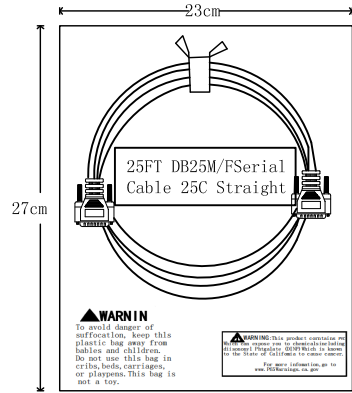

behind side

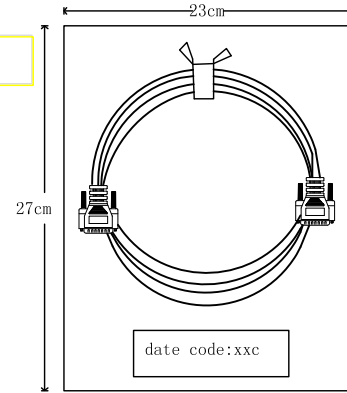

Bag Material: Poly Ethylene

Print content

Side Mark

		<b>RoHS Compliant</b>
P/N: 180209		
Q'TY: 30	PCS	
N.W.: 16.50	KGS	
G.W.: 17.5	KGS	
Date Code:	XX-XXXX	
Vender Code:	PS00523	

Main Mark

P/O:  
P/N: 180209  
Q' TY: 30PCS  
C/NO. : Dxxx  
MADE IN CHINA

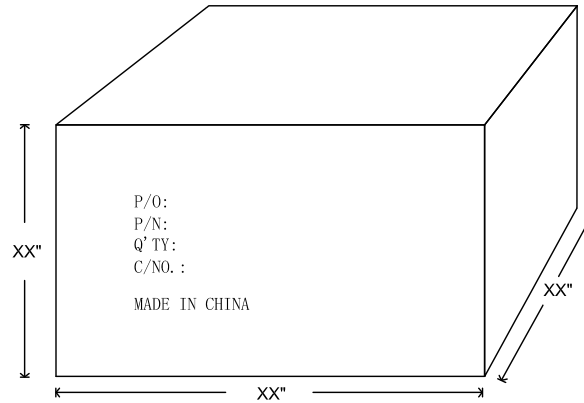

Carton Size: 21.26\*14.57\*8.67  
Carton Quantity: 30PCS  
Carton Weight: 38.5LBS

DRAWN BY	DATE: 2025.2.6	DESCRIPTION: 25FT DB25M/FSerial Cable 25C Straight	
CHECKED BY	SHEET 1 of 1	ITEM NO.	180209
APPROVED BY	SCALE 1:1	REV. 00	UNIT: mm