

NOTE: ALL MATERIAL COMPLIANT ROHS STANDARD

REVISION INFORMATION			
Rev.	Rev. Date	Modified By	Brief Description

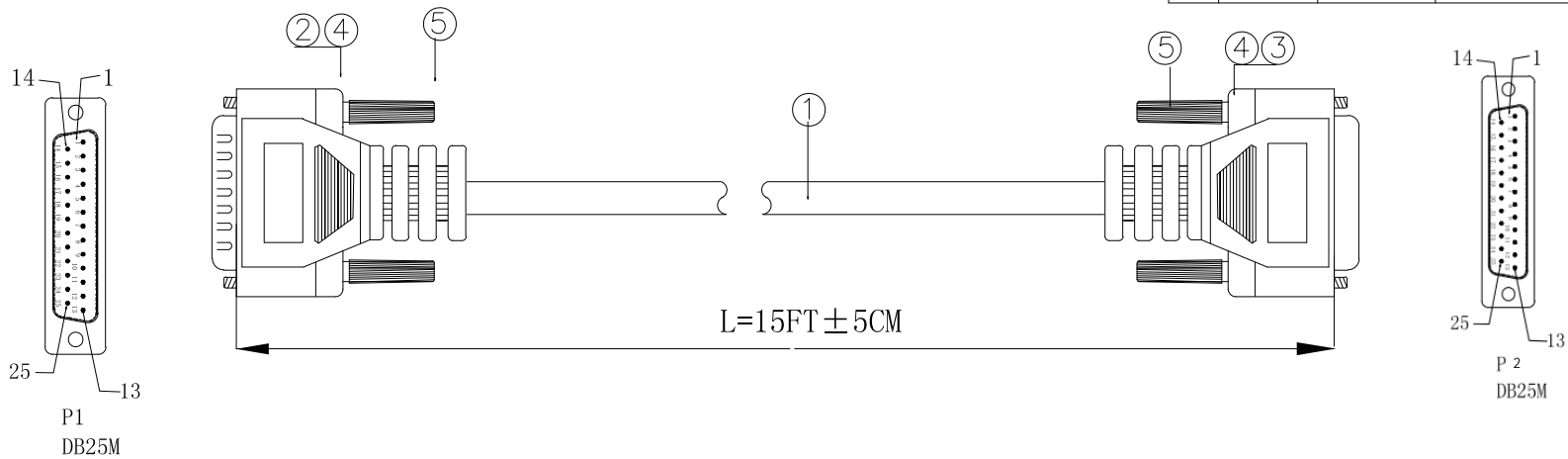

Technical requirements

1 electrical characteristics:
Electrical testing should be finished 1.1, cannot have short circuit breakers, intermittent contact, insulation, dislocation, contact resistance and electrical adverse circumstances.

1.2 electrical test conditions
conduction impedance: 10Ω

Insulation resistance: 10Ω / 300V

2 appearance requirements:

There can be no external formwork 2.1, full mould flow lines and shrink wait for a phenomenon.

2.2 wire surface clean, smooth, do not have clear off color and scratches.

Do not have 230 terminals oxidation and electric plating falls off phenomenon.

Packing:

3.Blank PE bag + TAB, a single round packaging.

PIN ASSIGNMENT:

DB25M	DB25F	DB25M	DB25F
1 — BLACK	1	16 — WHITE+ORANGE	16
2 — BROWN	2	17 — YELLOW+BLACK	17
3 — RED	3	18 — WHITE+GREEN	18
4 — ORANGE	4	19 — WHITE+BLUE	19
5 — YELLOW	5	20 — WHITE+PURPLE	20
6 — GREEN	6	21 — GRAY+BLACK	21
7 — BLUE	7	22 — PINK+BLACK	22
8 — PURPLE	8	23 — RED+BLACK	23
9 — GRAY	9	24 — ORANGE+BLACK	24
10 — WHITE	10	25 — GREEN+BLACK	25
11 — PINK	11	Shell	Shell
12 — PALE GREEN	12		
13 — WHITE+BLACK	13		
14 — WHITE+BROWN	14		
15 — WHITE+RED	15		

Wire Details

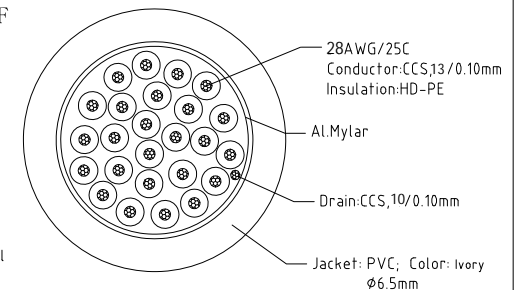

1).Material List :

NO.	PART NAME	SPECIFICATION DESCRIPTION	QTY	UNIT
⑤	SCREW	2.3*47MM color screw stem	4	PCS
④	Outer Moaldding	45P PVC Ivory color plugs	NA	KG
③	Connector	DB 25PF two rows of blue iron shell plating nickel	1	PCS
②	Connector	DB 25PM two rows of blue iron shell plating nickel	1	PCS
①	Wire	13/0.1CCS×25C+D+A+PVC,Ivory,OD6.5mm	15	ft

DRAWN BY	DATE: 2025. 2. 8	DESCRIPTION: 15FT DB25M/M Serial Cable 25C Straight
CHECKED BY	SHEET 1 of 1	ITEM NO. 180203
APPROVED BY	SCALE 1:1	REV. 00 UNIT: mm

NOTE: CARTON MATERIAL MUST BE A=A

REVISION INFORMATION			
Rev.	Rev. Date	Modified By	Brief Description

front side

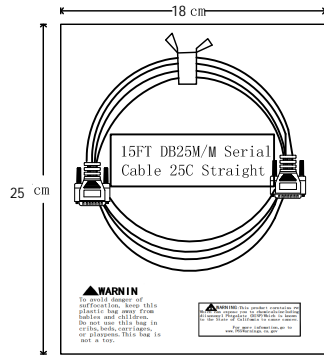

behind side

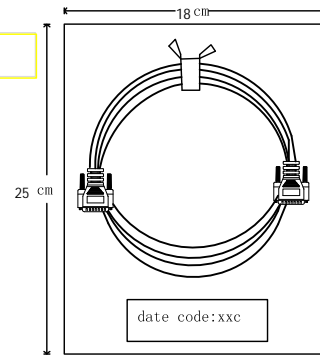

Bag Material: Poly Ethylene

Print content

Side Mark

		RoHS Compliant
P/N: 180203		
Q'TY: 50	PCS	
N.W.: 18.00	KGS	
G.W.: 19.3	KGS	
Date Code:	XX-XXXX	
Vender Code:	PS00523	

Main Mark

P/O: P/N: 180203 Q' TY: 50PCS C/NO. : Dxxx MADE IN CHINA
--

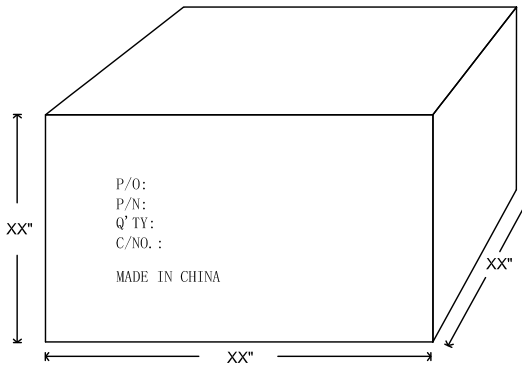

P/O:
P/N:
Q' TY:
C/NO. :

MADE IN CHINA

Carton Size: 21.26*14.57*8.67
 Carton Quantity: 50PCS
 Carton Weight: 42.46LBS



DRAWN BY	DATE: 2025.2.8	DESCRIPTION: 15FT DB25M/M Serial Cable 25C Straight
CHECKED BY	SHEET 1 of 1	ITEM NO. 180203
APPROVED BY	SCALE 1:1	REV. 00 UNIT: mm