

SCALE 1/1

Specification :

Material :

1. RJ45 Jack :
 - 1-1. Housing : Zinc Die-Casting with Nickel plated.
 - 1-2. Contact Bracket : PC, UL 94-V2, Transparent color.
2. RJ45 Jack Contact :
 - 2-1. Material : Phosphor Bronze with Nickel plated.
 - 2-2. Finish : 50 micro-inch Gold plated on Plug contact area.
3. Cap A&B : Zinc Die-Casting with Nickel plated.
4. IDC :
 - 4-1. Housing : PC+Glass Fiber, Grey color(RAL7035), UL 94-V2.
 - 4-2. Terminal : Phosphor Bronze with Tin plated.
5. IDC Cap : PC+Glass Fiber, White color, UL 94-V2.
6. Clip : Stainless Steel.
7. Grounding Contact : Zinc Die-Casting with Nickel plated.
8. PCB : FR4, UL 94-V0.

Performance :

- a. T568A & T568B wiring.
- b. Insertion Force : 30N max. (IEC 60603-7-5).
- c. Retention Strength : 7.7 kg between Jack and Plug.
- d. Operating Temperature : -10°C to 60°C. (ISO/IEC 11801, ANSI/TIA/EIA 568 B.2).
- e. Life(mating cycles) :
 - e-1. Jack : 750 cycles min. (ISO/IEC 11801, IEC 60603-7-5).
 - e-2. IDC : Suitable for 23-26 AWG stranded and solid wire, compatible with both 110 & Krone punch down tool.
 - e-3. Tool-less : When using the IDC Cap for wire management.
- f. The Cat.6A transmission performance is in compliance with the ANSI/TIA/EIA 568 C.2 standard.

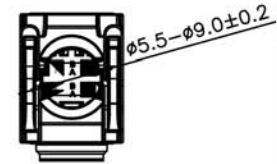
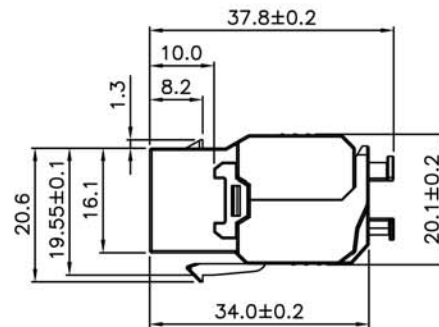
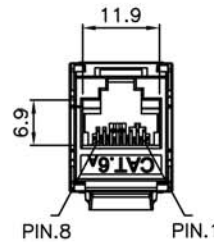
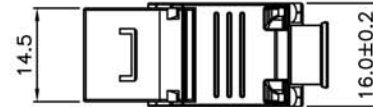

GENERAL TOLERANCE OF DIMENSIONS X.XXX ±0.005 X.XX ±0.05 X.X ±0.1	DRAWING	12.APR.2011	CHP	<h1>101722</h1>
	CHECK	12.APR.2011	DAY	
	APPROVAL	12.APR.2011	JAIMY	
	DATE	NAME	ITEM NO.: AADBC0211600015	
SCALE	1/1 (A4)	UNIT	mm	DES.: CAT.6A FULL SHIELDED KEYSTONE JACK
DRAWING NO.		DRAWING CLASSIFICATION		
SHEET		1 OF 1		A2