

NOTE:ALL MATERIAL COMPLIANT ROHS STANDARD

REVISION INFORMATION

Rev.	Rev. Date	Modified By	Brief Description
2.0	2016-4-28	Pillar	Add labels on packaging
3.0	2016-7-28	Pillar	Change the Mold
4.0	2017/08/21	Ndq	Add one bag to the packing

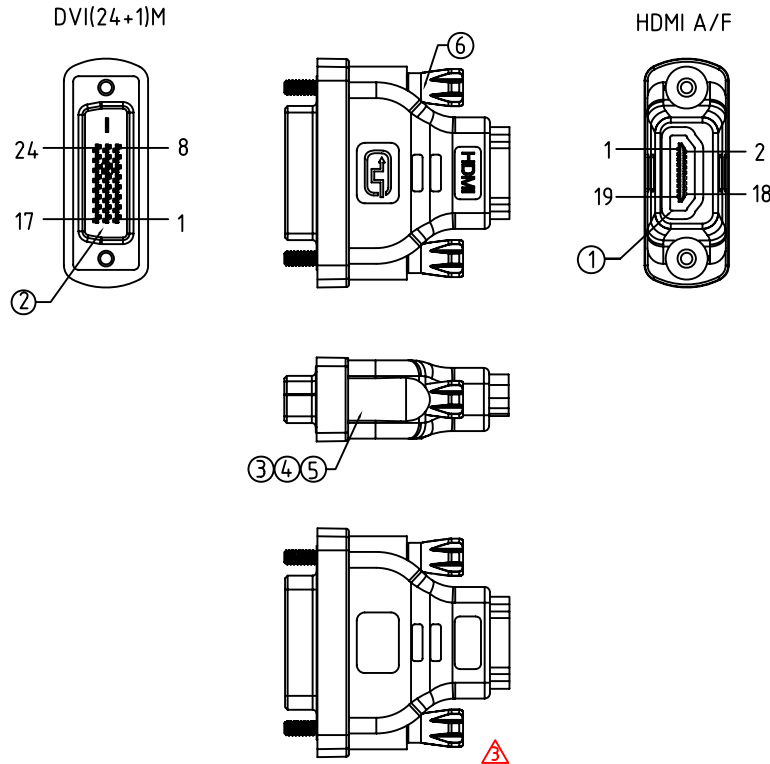

Electrical character:

- 1)100% Open/short/Intermittent testing
- 2)Withstanding voltage:DC 300V AT 10ms.
- 3)Insulation resistance:10M Ohm(min)
- 4)Conductive resistance:3 Ohm(max)

PIN ASSIGNMENT

HDMI A F	DVI
1	2
2	3
3	1
4	10
5	11
6	9
7	18
8	19
9	17
10	23
11	22
12	24
15	6
16	7
17	15
18	14
19	16
SHELL	SHELL

①	Conn	HDMI A F,PIN G/F,Black,Shell Gold Plated		
②	Conn	DVI-D(24+1) M,PIN G/F,Black,Shell Gold Plated		
③	Innrmold	PE,Low density		
④	Overmold	PVC,45Pa,Black		
⑤	PCB	PCB		
⑥	Thumbscrew	#4-40UNC,Nickel Plated,Molding Black PVC		
NO.	PART NAME	SPECIFICATION DESCRIPTION	QTY	UNIT

Unless specified on the drawing, tolerances are per the follows:

.	+1
.x	+0,2
.xx	+0.05

DRAWN BY	DATE: 2017/08/21	DESCRIPTION: DVI-D(24+1) TO HDMI AF Adapter
CHECKED BY	SHEET 1of2	ITEM NO. 181241
APPROVED BY	SCALE None	REV. 4.0 UNIT:mm

NOTE: CARTON MATERIAL MUST BE A=A

REVISION INFORMATION			
Rev.	Rev. Date	Modified By	Brief Description
2.0	2016-4-28	Pillar	Add labels on packaging
3.0	2016-7-28	Pillar	Change the Mold
4.0	2017/08/21	Ndq	Add one bag to the packing

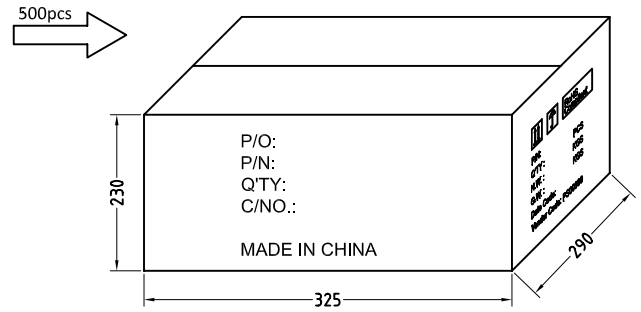
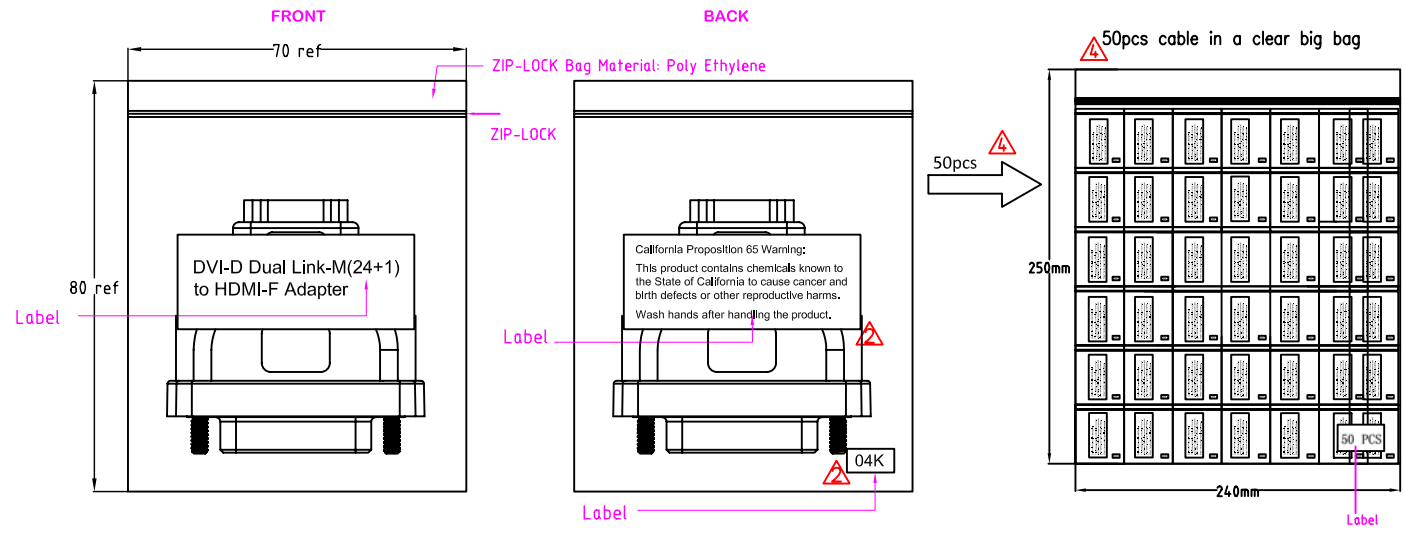

MAIN MARK

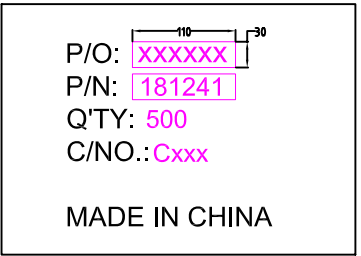

SIDE MARK

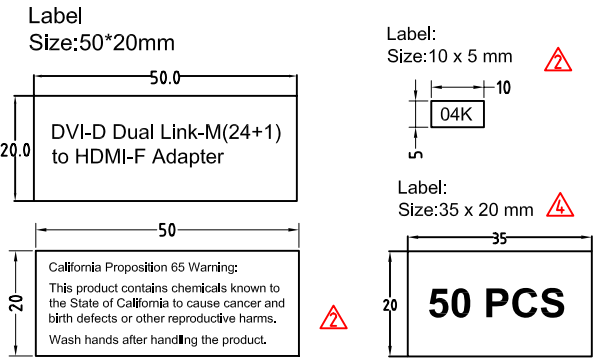
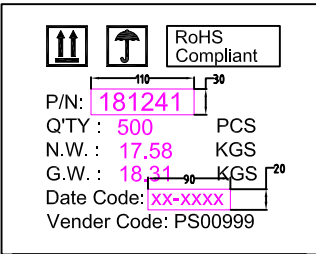

Carton Size: 12.80"(L)*11.42"(W)*9.06"(H)
 Carton Quantity: 500 pcs
 Carton Weight: 40.38 LBS

Packing Instruction:

1. Each product in a POLY-BAG, The label is attached to the PE bag. 50pcs cable in a clear big bag, The label is attached to the PE bag,
2. Use a waterproof bag to pack the products before going into master carton. Make sure each individual cable is staggered and positioned tidily. A paperboard is needed in both the bottom and the top of the products.
3. See shipping mark on the left.

DRAWN BY	DATE: 2017/08/21	DESCRIPTION: DVI-D(24+1) TO HDMI AF Adapter	
CHECKED BY	SHEET 2of2	ITEM NO. 181241	
APPROVED BY	SCALE None	REV.4.0	UNIT:mm