

NOTE: ALL MATERIAL COMPLIANT ROHS STANDARD

REVISION INFORMATION			
Rev.	Rev. Date	Modified By	Brief Description
A/0	14-03-10	Y0310A	NEW DRAWING

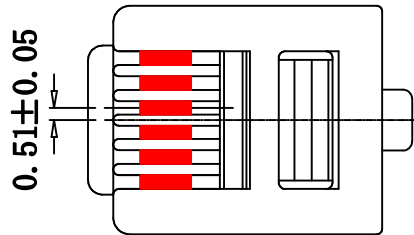

MP6P6C R

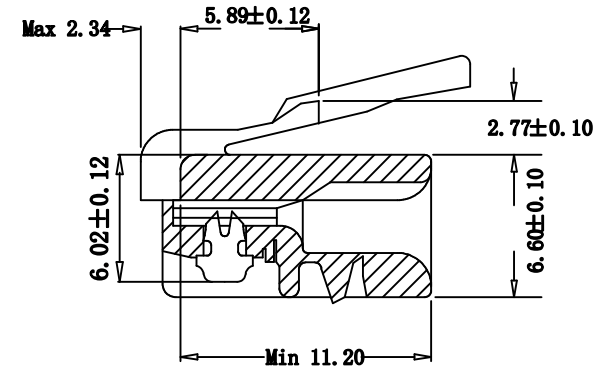
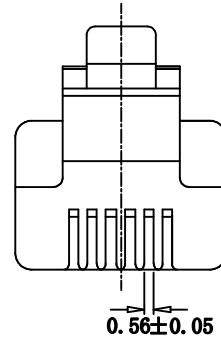

SPECIFICATIONS

MANUFACTURER	BON;BCI OR CZT
PART NO.	CH106MP6F OR MODELS 6P-6C R
UL REF:	E159371;UL 498 NO,E129580 OR E134299
CSA REF	LR 90513 OR LR 96654
HOUSING	POLY CARBONATE(PC) UL94V2 NO. E919153
CONTACT BLADE	HIGH STRENGTH COPPER ALLOY
MATERIAL	100 MICRON NICKEL UNDERPLATED
PLATING TYPE	8% PHOSPHOR BRONZE
PLATING THICKNESS:	(FU") GOLD PLATED
OPERATING TEMP	-40° C TO 125° C
CURRENT RATING	250V AC MAX AT 2A
DIELECTRIC	500V AC
INSULATION RES	500MEGAOHMS
TERMINATION RES	35 MAX AFTER ENVIRONMENTAL TESTS
TENSILE STRENGTH	20 LBS(89N)MIN
DURABILITY	500 MATING CYCLES
COMPLIES WITH FCC68/F	

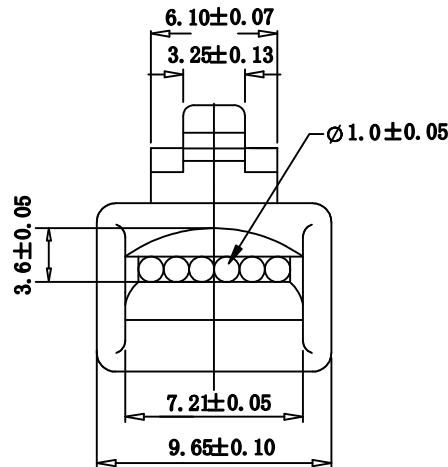

PART NO	DRAWING NO	BUYER COLOR	VENDOR COLOR	CUT LENGTH
170305	217-069-A			

⑦				
⑥				
⑤				
④				
③				
②				
①	PLUG	6P6C FU" ROUND	1	PCS
NO.	PART NAME	SPECIFICATION DESCRIPTION	QTY	UNIT



DRAWN BY:	DATE: 2014/03/10	DESCRIPTION: RJ12 6P6C FU" ROUND
CHECKED BY	SHEET 1 of 1	ITEM NO.170305
APPROVED BY	SCALE 1:1	REV. A/0 UNIT: mm