

REVISIONS

REV.	BY.	REVISIONS	DATE

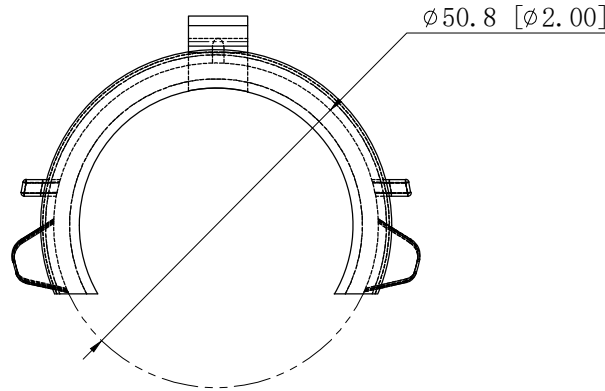
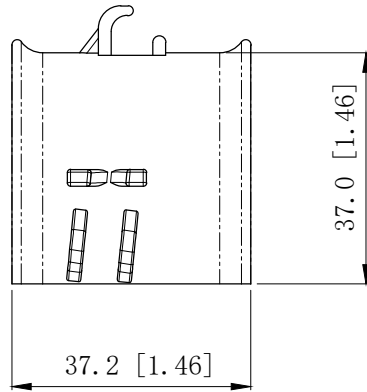
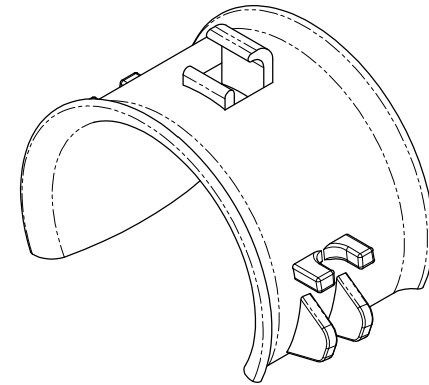
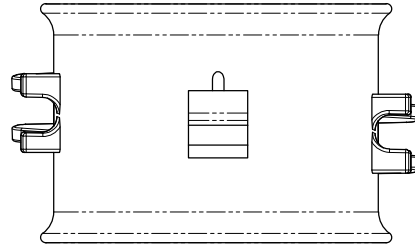

Package£ 100pcs/ctn
Carton Packing Only without PE self-sealing bag.

NOTES:

- 1.All dimensions in millimeters and [inches];
- 2.Material:PE ;
- 3.Free of sharp edge and burrs.max burr 0.127[0.005];

TOLERANCES UNLESS OTHERWISE SPECIFIED		NAME	DATE	
INCHES:	MILLIMETER	YUAN	2023. 3. 29	
ANGULAR:	ANGULAR:			TITLE
X.X: ±0.1	X: ±2.54			
X.XX: ±0.05	X.X: ±1.27			
X.XXX: ±0.008	X.XX: ±0.203			
MATERIAL		APPROVED (A)		
PE		APPROVED (Customer)		
FINISH				
		SIZE	DWG NO.	REV
		A4	104247	A
		SCALE: 1:1	PRINT DATE	REFERENCES
				SHEET 1 OF 1

