

NOTE: ALL MATERIAL COMPLIANT ROHS STANDARD

REVISION INFORMATION

Rev.	Rev. Date	Modified By	Brief Description

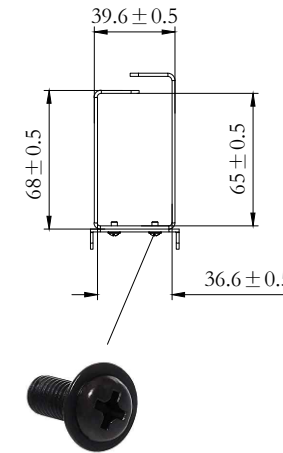
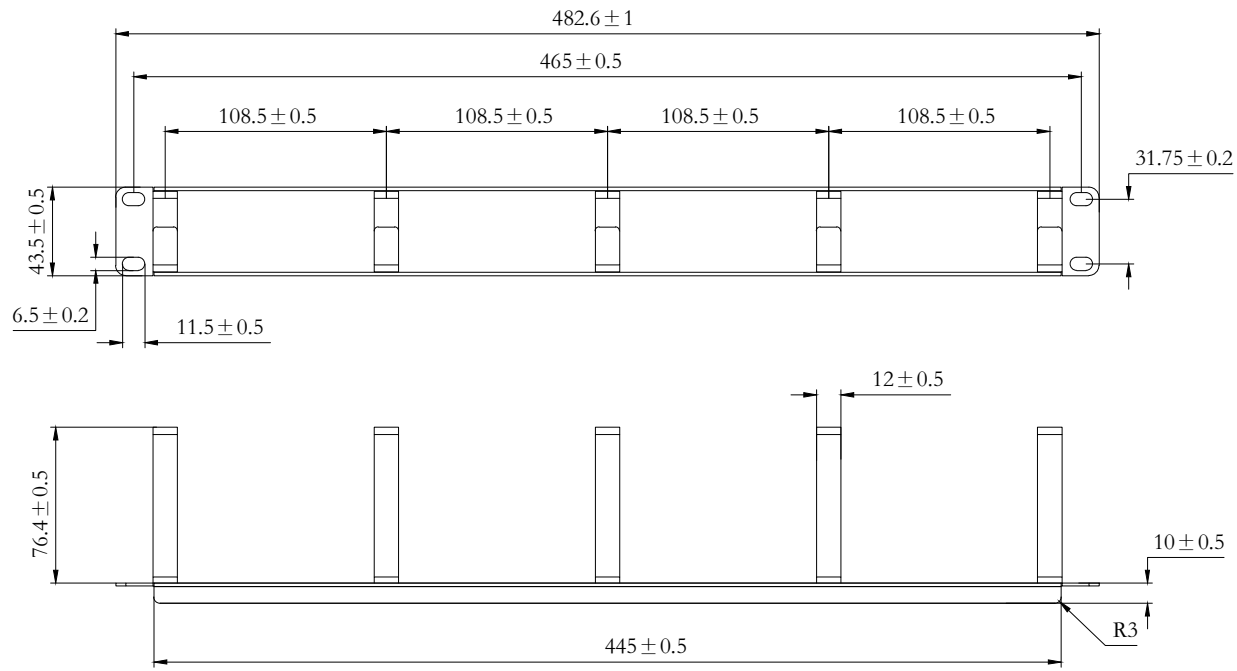

Specification:

Material :

1. Panel : SPCC, 1.4mm thickness with Black (RAL 9005) color painted.
2. Metal wire ring : SPCC, 1.4mm thickness with Black (RAL 9005) color painted.

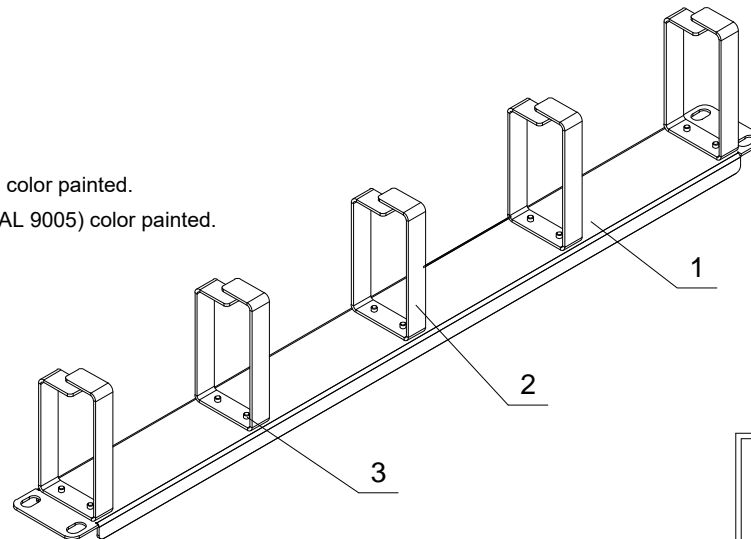

NO.	PART NAME	SPECIFICATION DESCRIPTION	QTY	UNIT
③	Screws	M3 xL5 mm(black)	10	PCS
②	Metal wire ring	76.4*39.6*12 mm	5	PCS
①				

DRAWN BY	DATE: 2020/08/18	DESCRIPTION: 1 UNIT Cable Management
CHECKED BY	SHEET 1of1	ITEM NO. 102242
APPROVED BY	SCALE 1:1	REV. 00 UNIT:mm

NOTE: CARTON MATERIAL MUST BE A=A

REVISION INFORMATION			
Rev.	Rev. Date	Modified By	Brief Description

Inside the box

Description: 1U Cable Management
1.75"x19", Metal Ring
QTY: 1 PCS

typeface:Arial
Sticker size : 100*35mm

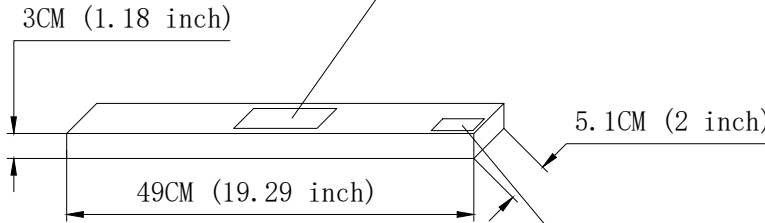

Unit package
Size: 49*5.1*3 CM (19.29*2*1.18inch)
Weight : 1.067 LBS(0.484KG)
QTY : 1PCS

AT the bottom of the box

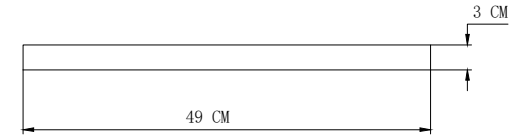

WARNING: This product contains PVC
Which can expose you to chemicals including
disinonyl phthalate (DINP) which is known
to the State of California to cause cancer.
For more information, go to
www.P65Warnings.ca.gov

typeface:Arial
Sticker size : 50*20mm

Main Mark

P/O :
P/N : 102242
QTY : 30 PCS
C/NO :
MADE IN CHINA

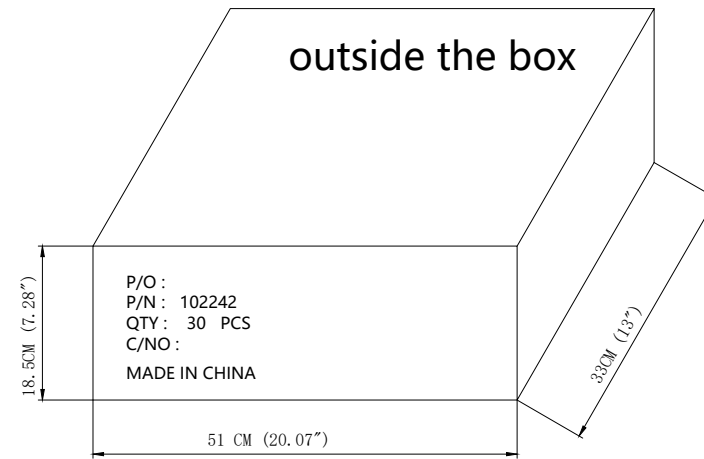

outside the box

P/O :
P/N : 102242
QTY : 30 PCS
C/NO :
MADE IN CHINA

Carton Size : 51CM(20.07") X 33 CM(13") X 18.5 CM(7.28")
Carton Quantity : 30 Pcs
Carton Weight : 33.6 LBS(15.2Kg)

Side Mark

P/N: 102242
QTY: 30 PCS
N.W: 14.5 KGS
G.W: 15.2 KGS
Date code:
Vender Code:



NO.	PART NAME	SPECIFICATION DESCRIPTION	QTY	UNIT
③				
②				
①				

DRAWN BY	DATE: 2020/08/14	DESCRIPTION: 1U Cable Management 1.75"x19", Metal Ring
CHECKED BY	SHEET 1of1	ITEM NO. 102242
APPROVED BY	SCALE 1:1	REV. 00 UNIT:mm

NOTE:ALL MATERIAL COMPLIANT ROHS STANDARD

REVISION INFORMATION

Rev.	Rev. Date	Modified By	Brief Description

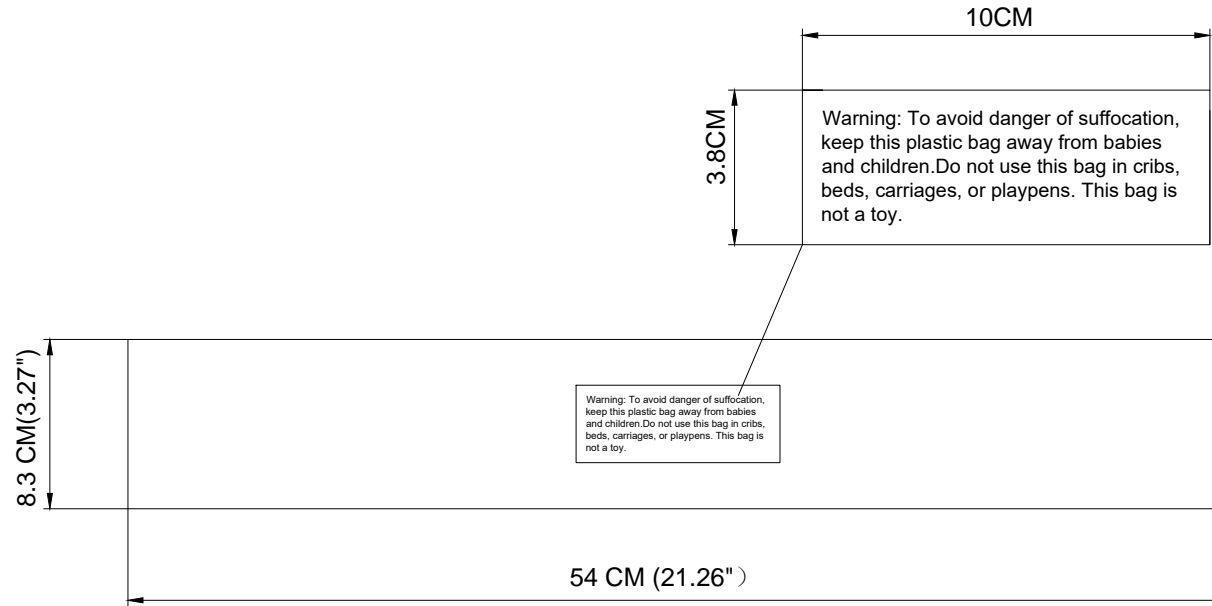

NO.	PART NAME	SPECIFICATION DESCRIPTION	QTY	UNIT
①				
②				
③				

DRAWN BY	DATE: 2020/08/14	DESCRIPTION: PE bag and warning(21.26**3.27")		
CHECKED BY	SHEET 1of1	ITEM NO.		
APPROVED BY	SCALE 1:1	REV. 00	UNIT:mm	