

NOTE: ALL MATERIAL COMPLIANT ROHS STANDARD

REVISION INFORMATION			
Rev.	Rev. Date	Modified By	Brief Description

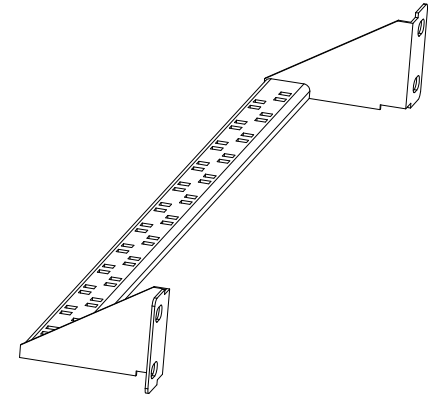
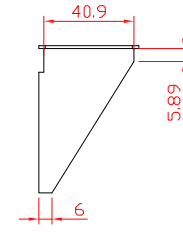
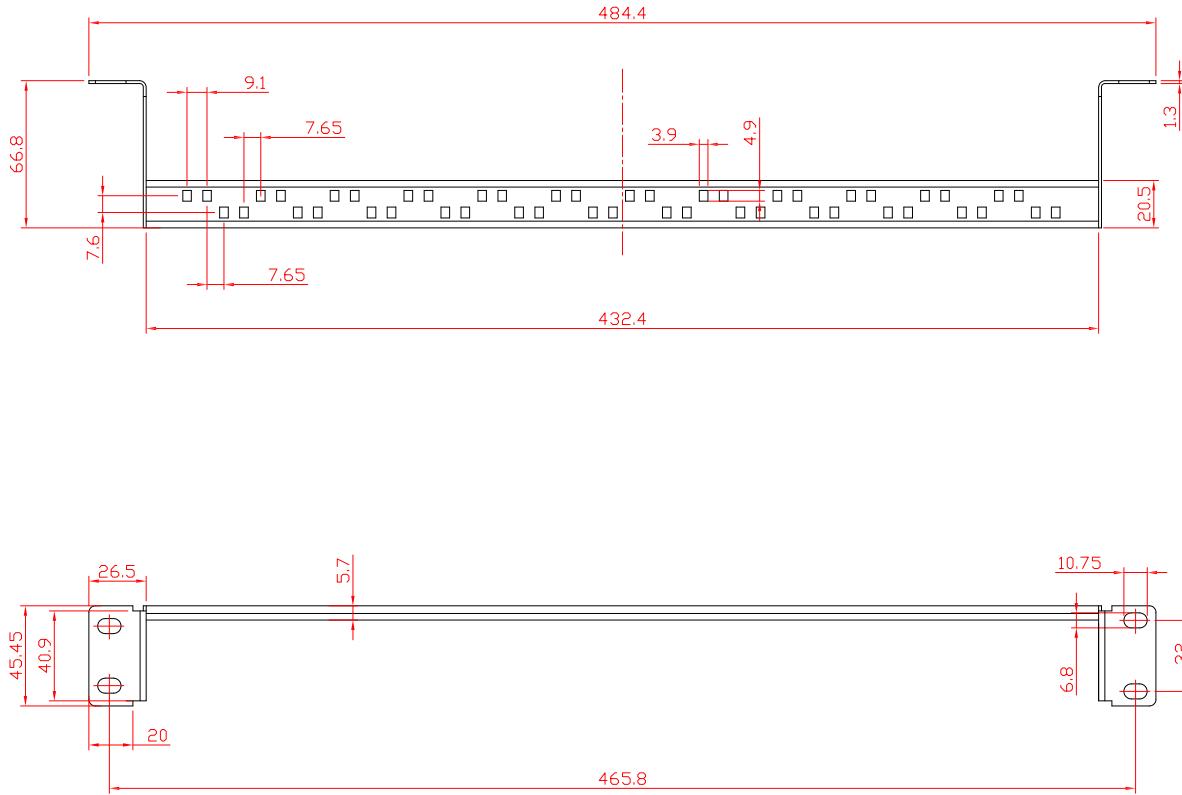

Technical requirement:

1. Appearance may not have burrs, deformation, scratches, stains and other defects.
2. Parts require deburring;
3. Products of electroplating, bright surface, no wave, miscellaneous points, yellow, grinning, no mechanical scratches and so;
4. Size for size after blasting, iron plate thickness control in the following 1.5 to 1.5
5. Weight:



NO.	PART NAME	SPECIFICATION DESCRIPTION	QTY	UNIT
③				
②				
①				

DRAWN BY	DATE: 2019/8/12	DESCRIPTION: 1U Cable Management
CHECKED BY	SHEET 1 of 2	ITEM NO. 102219
APPROVED BY	SCALE 1:3	REV. 00 UNIT: mm

NOTE: ALL MATERIAL COMPLIANT ROHS STANDARD

REVISION INFORMATION			
Rev.	Rev. Date	Modified By	Brief Description

Inside the box color:white

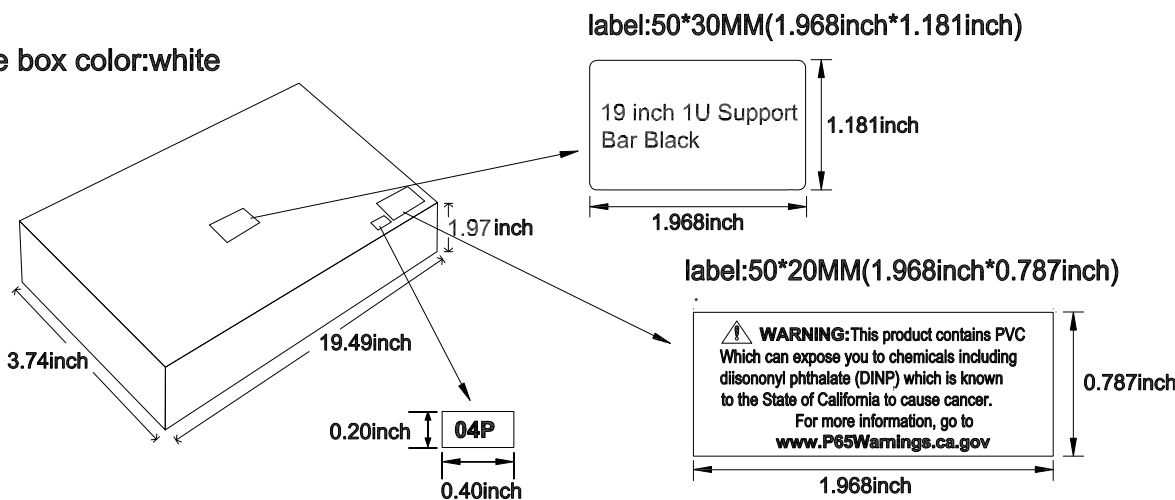

At the bottom of the box

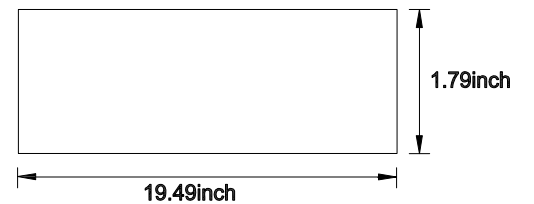

Side Mark

P/N: 102219
 QTY: 25 PCS
 N.W.: 5 KGS
 G.W.: 6 KGS
 Date Code: 24-2019
 Vender Code: PS01083

Unit package

Size: 49.5X9.5X5 CM (19.49X3.74X1.97inch)
 Weight: 1.06 LBS(0.48KG)
 QTY.: 1 PCS

Main Mark

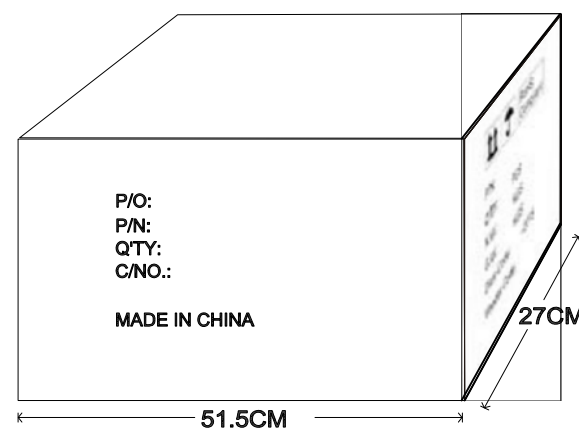

Carton Size: 51.5X27X51CM
 Carton Quantity: 25 PCS
 Carton Weight: 31.7 LBS

NO.	PART NAME	SPECIFICATION DESCRIPTION	QTY	UNIT
③				
②				
①				

DRAWN BY	DATE: 2019/8/12	DESCRIPTION: 1U Cable Management
CHECKED BY	SHEET 1 of 2	ITEM NO. 102219
APPROVED BY	SCALE 1:3	REV. 00 UNIT: mm