

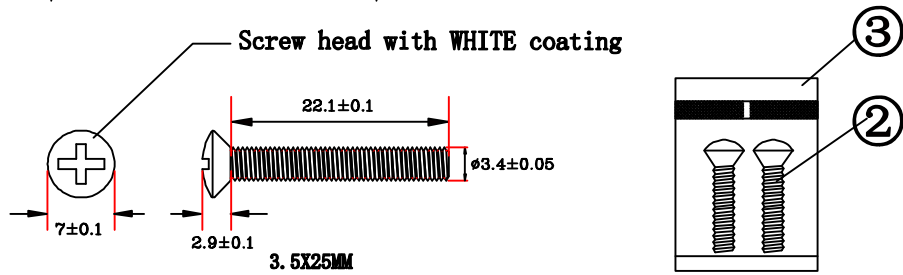

NOTE: ALL MATERIAL COMPLIANT ROHS STANDARD

| REVISION INFORMATION | | | |
|----------------------|-----------|-------------|-------------------|
| Rev. | Rev. Date | Modified By | Brief Description |
| A/0 | 14-03-10 | Y0310H | NEW DRAWING |
| A/1 | 14-06-30 | B0626B | CHANGE THE SCREW |

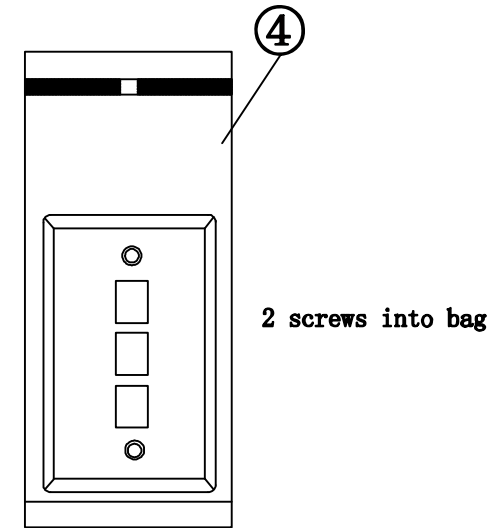
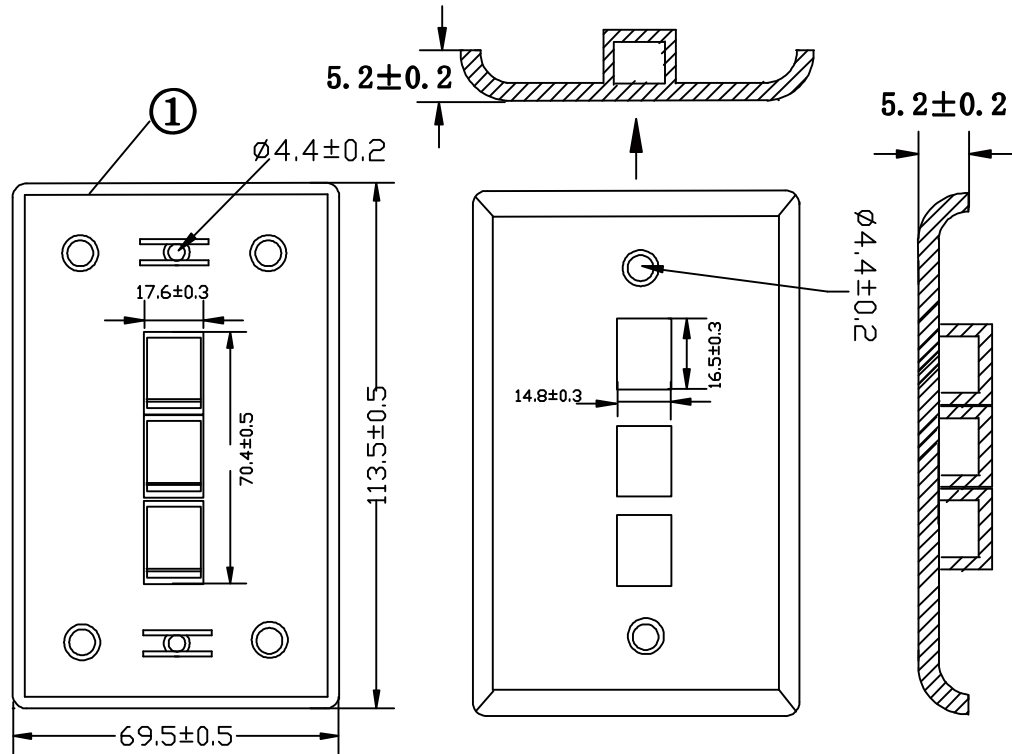

| PART NO | DRAWING NO | BUYER COLOR | VENDOR COLOR |
|----------|------------|-------------|--------------|
| 101833WT | 217-059-A | | WH-S15 |
| | | | |
| | | | |

| NO. | PART NAME | SPECIFICATION DESCRIPTION | QTY | UNIT |
|-----|-----------|--|-----|------|
| ⑦ | | | | |
| ⑥ | | | | |
| ⑤ | | | | |
| ④ | Bag:B | 180X80MMX04 | 1 | PCS |
| ③ | Bag:A | 30X50MMX04 | 1 | PCS |
| ② | Screw | BC3.5X25MM Screw head with Color coating | 2 | PCS |
| ① | CA03 | ABS NOUL COLOR:WH-S15 | 1 | PCS |



| | | |
|-------------|---------------------|-----------------------------|
| DRAWN BY: | DATE: 2014/06/30 | DESCRIPTION: CA03 WH-S15 |
| CHECKED BY | SHEET 1 of 1 | ITEM NO. |
| APPROVED BY | SCALE 1:1 | REV. A/1 |

