

NOTE:ALL MATERIAL COMPLIANT ROHS STANDARD

REVISION INFORMATION

Rev.	Rev. Date	Modified By	Brief Description
1.0	2016/04/11	Pillar	Add labels on packaging
2.0	2019/06/03	Panther	Revise Warning Lable

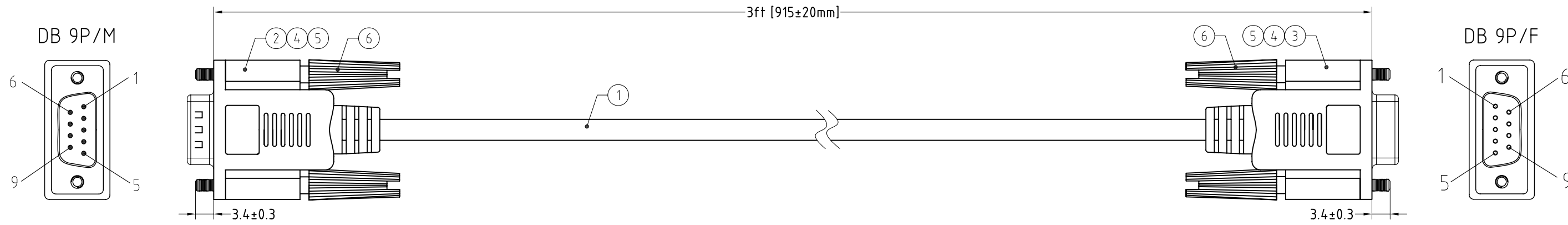

Electrical character:

- 1)100% Open/short/Intermittent testing
- 2)Withstanding voltage:DC 300V AT 10ms.
- 3)Insulation resistance:5M Ohm(min)
- 4)Conductive resistance:5 Ohm(max)

Wire Details

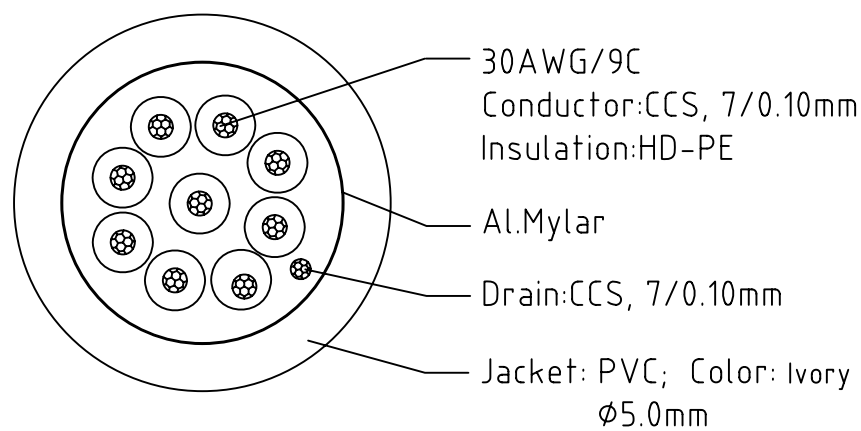

PIN ASSIGNMENT:

DB 9P/M	DB 9P/F
1	red 1
2	green 2
3	blue 3
4	brown 4
5	orange 5
6	yellow 6
7	purple 7
8	grey 8
9	black 9
SHELL	drain SHELL

NO.	PART NAME	SPECIFICATION DESCRIPTION	QTY	UNIT
①	Cable	30#(7/0.10CCS)*9C+D+A+PVC,Ivory,OD5.0mm		
②	Conn	DB 9P/M,PIN G/F,Blue Insulation,Steel-Shell(Nickel Plated),Solder type		
③	Conn	DB 9P/F,PIN G/F,Blue Insulation,Steel-Shell(Nickel Plated),Solder type		
④	Innermold	PE,Low density		
⑤	Overmold	PVC,45Pa,Ivory		
⑥	Thumbscrew	#4-40UNC,Ø4.0*L37.4mm,Nickel Plated,Molding PVC(Ivory)		

Unless specified on the drawing, tolerances are per the follows:

.	+1
.X	+0.2
.XX	+0.05

DRAWN BY	DATE: 2019/06/03	DESCRIPTION: DB 9P M TO F Serial Cable
CHECKED BY	SHEET 1of2	ITEM NO. 180224
APPROVED BY	SCALE None	REV. 2.0 UNIT:mm

NOTE: CARTON MATERIAL MUST BE A=A

REVISION INFORMATION			
Rev.	Rev. Date	Modified By	Brief Description
1.0	2016/04/11	Pillar	Add labels on packaging
2.0	2019/06/03	Panther	Revise Warning Label

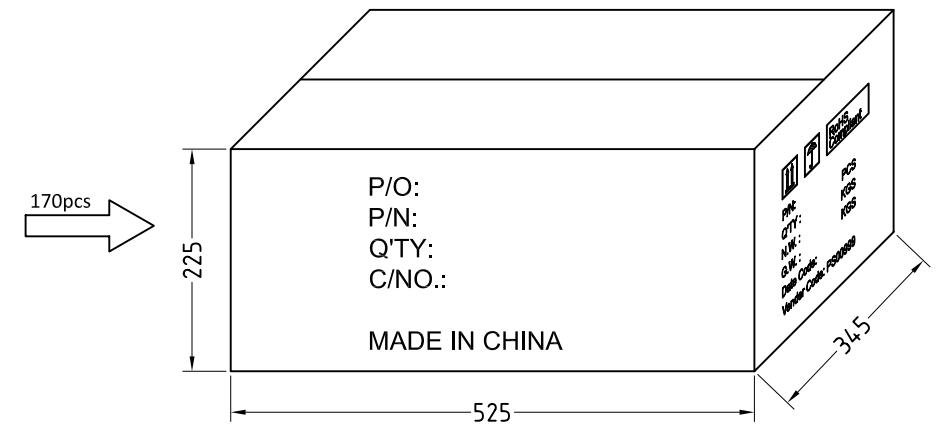
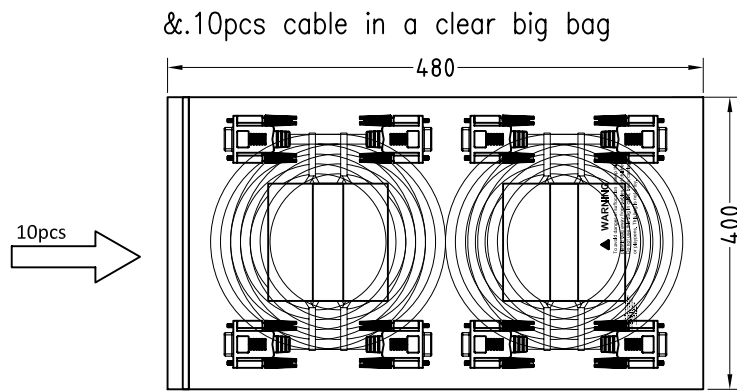
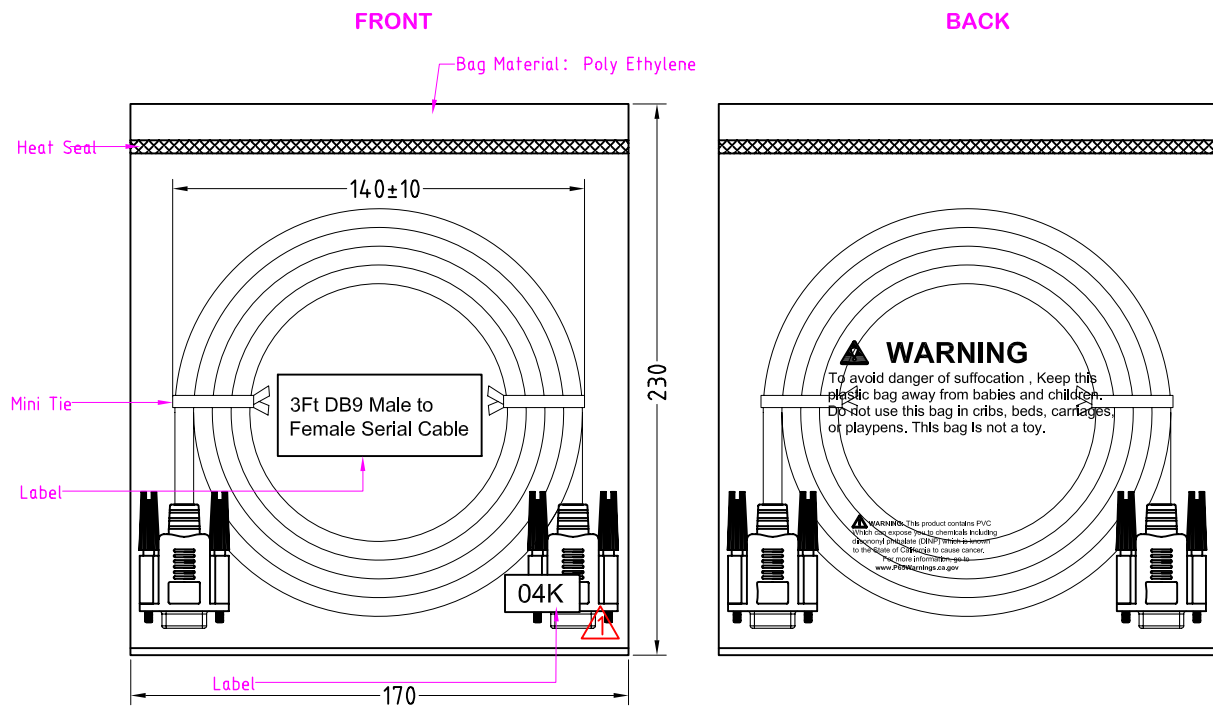

MAIN MARK

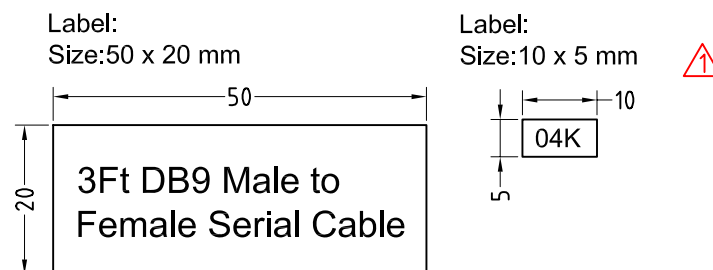
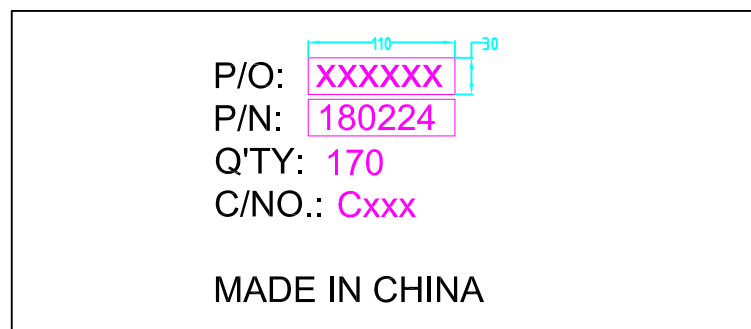

Packing Instruction:

1. First of all, coil the cable (see attached). Secure the cable with cable tie, and then pack each cable with an individual PE bag. 10pcs cable in a clear big bag, The label is attached to the PE bag.
2. Seal the PE bag with heat sealing machine.
3. Use a waterproof bag to pack the products before going into master carton. Make sure each individual cable is staggered and positioned tidily. A paperboard is needed in both the bottom and the top of the products.
4. See shipping mark on the left.

SIDE MARK

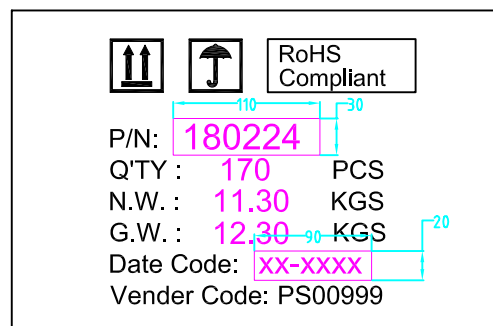

Carton Size: 20.67"(L)*13.58"(W)*8.86"(H)
 Carton Quantity: 170 pcs
 Carton Weight: 27.13 LBS

DRAWN BY	DATE: 2019/06/03	DESCRIPTION: DB 9P M TO F Serial Cable
CHECKED BY	SHEET 2of2	ITEM NO. 180224
APPROVED BY	SCALE None	REV. 2.0 UNIT:mm