

NOTE: ALL MATERIAL COMPLIANT ROHS STANDARD

REVISION INFORMATION			
Rev.	Rev. Date	Modified By	Brief Description

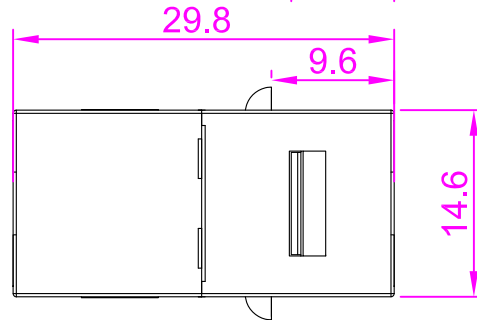
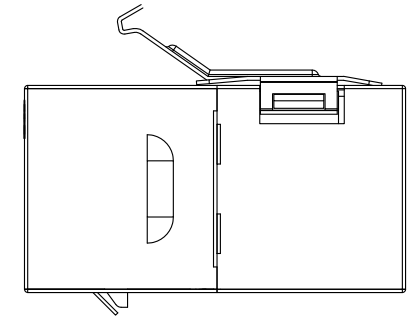
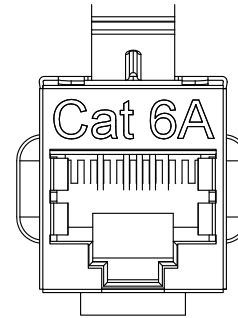
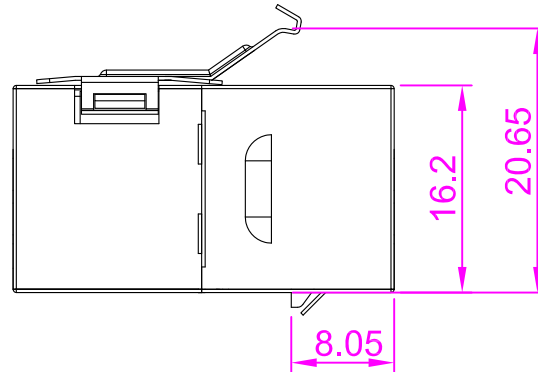
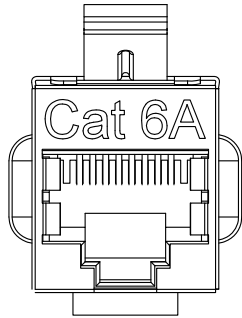
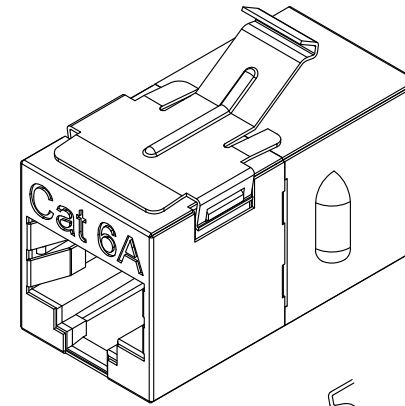
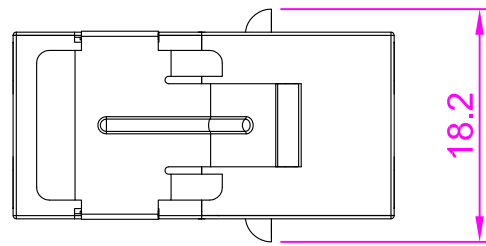

MATERIAL

HULL : Phosphor Bronze C5191R-H.
 JACK HOUSING: ABS UL94V-0.
 SPRING PIN: PHOSPHOR BRONZE C5210-EH, T=0.35MM;
 PLATING NICKEL UNDERCOAT,
 BESIDES PLATING 50U" GOLD OVER THE PLATED
 SURFACE ON CONTACT AREA.
 PCB: FR-4

PHYSICAL CHARACTERISTICS

INSERTION LIFE: 750 MATING CYCLES WITH FCC COMPLIANT 8P PLUG.
 CONTACT FORCE: 100 GRAMS WITH FCC COMPLIANT 8P PLUG.
 PLUG RETENTION FORCE: 11 LBF MIN.
 OPERATING TEMPERATURE RANGE: -10°C TO 60°C.
 STORAGE TEMPERATURE RANGE: -40°C TO 68°C.
 HUMIDITY: 10%-90% RH.

ELECTRICAL

INSULATION RESISTANCE : 500 MΩ MINIMUM.
 VOLTAGE PROOF (CONTACT TO CONTACT) : 1000 V AC.
 DC CURRENT RATING : 1.5 Amps.
 INPUT TO OUTPUT D.C. RESISTANCE FOR SHIELD : 100 mΩ MAXIMUM.
 INPUT TO OUTPUT D.C. RESISTANCE : 200 mΩ MAXIMUM.
 CONTACT RESISTANCE : 20 mΩ MAXIMUM.

NO.	PART NAME	SPECIFICATION DESCRIPTION	QTY	UNIT
③				
②				
①				

DRAWN BY	DATE: 2021/06/02	DESCRIPTION: Cat.6A Shielded Snap-In Type Inline Coupler	
CHECKED BY	SHEET 1 of 1	ITEM NO. 101719	
APPROVED BY	SCALE 2:1	REV. 00	UNIT: mm